

SKR TK 3uk

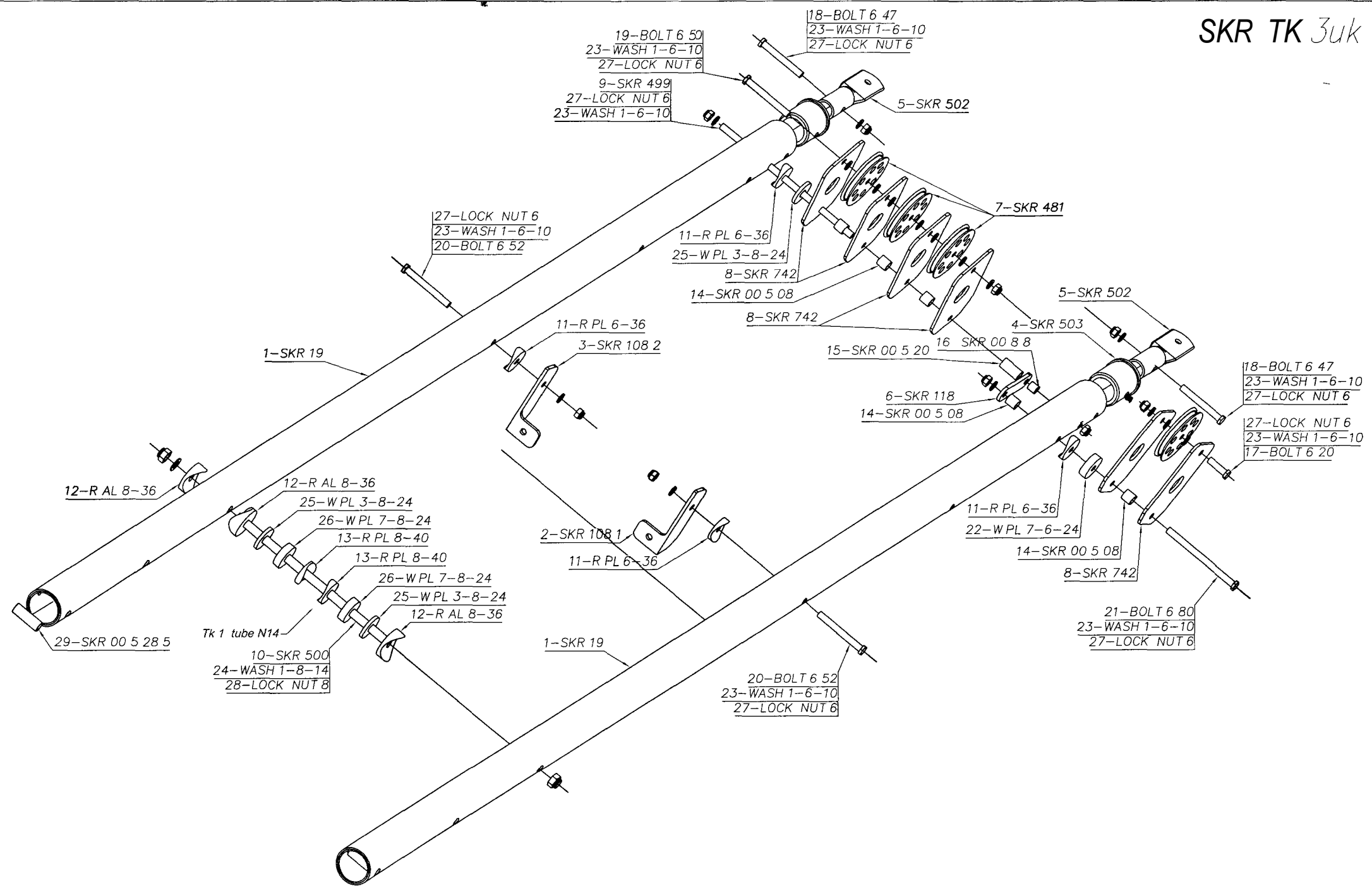

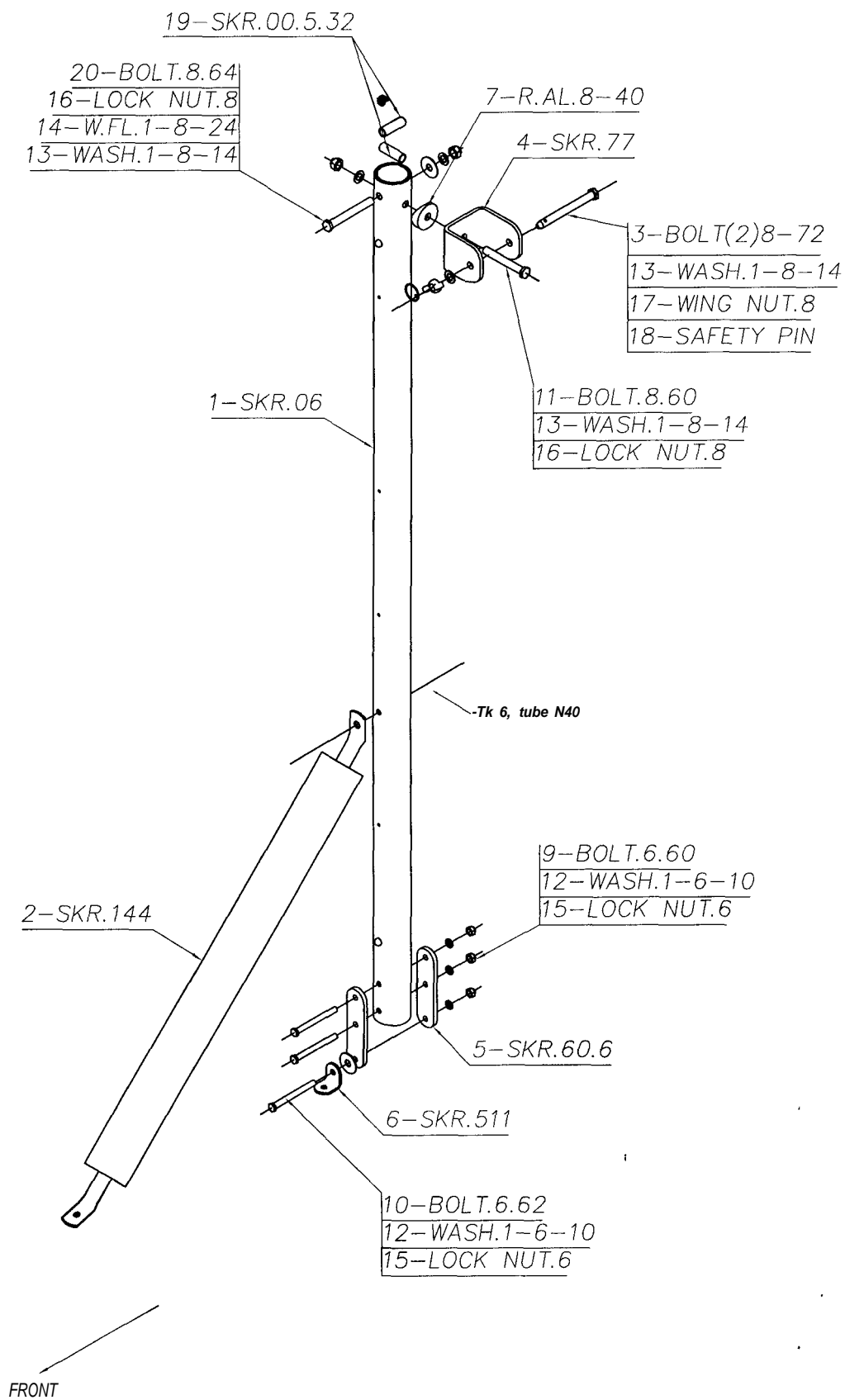

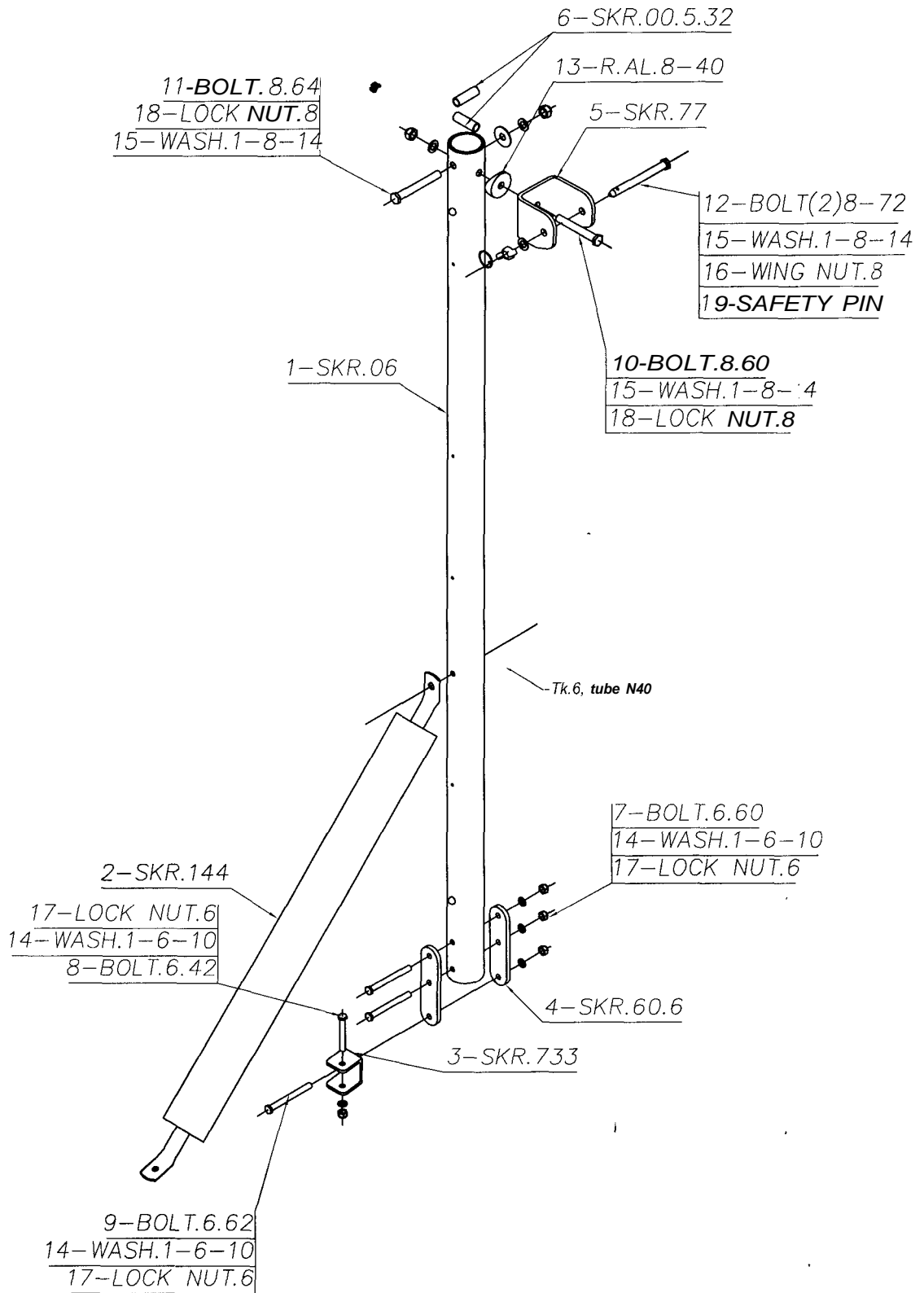

FRONT

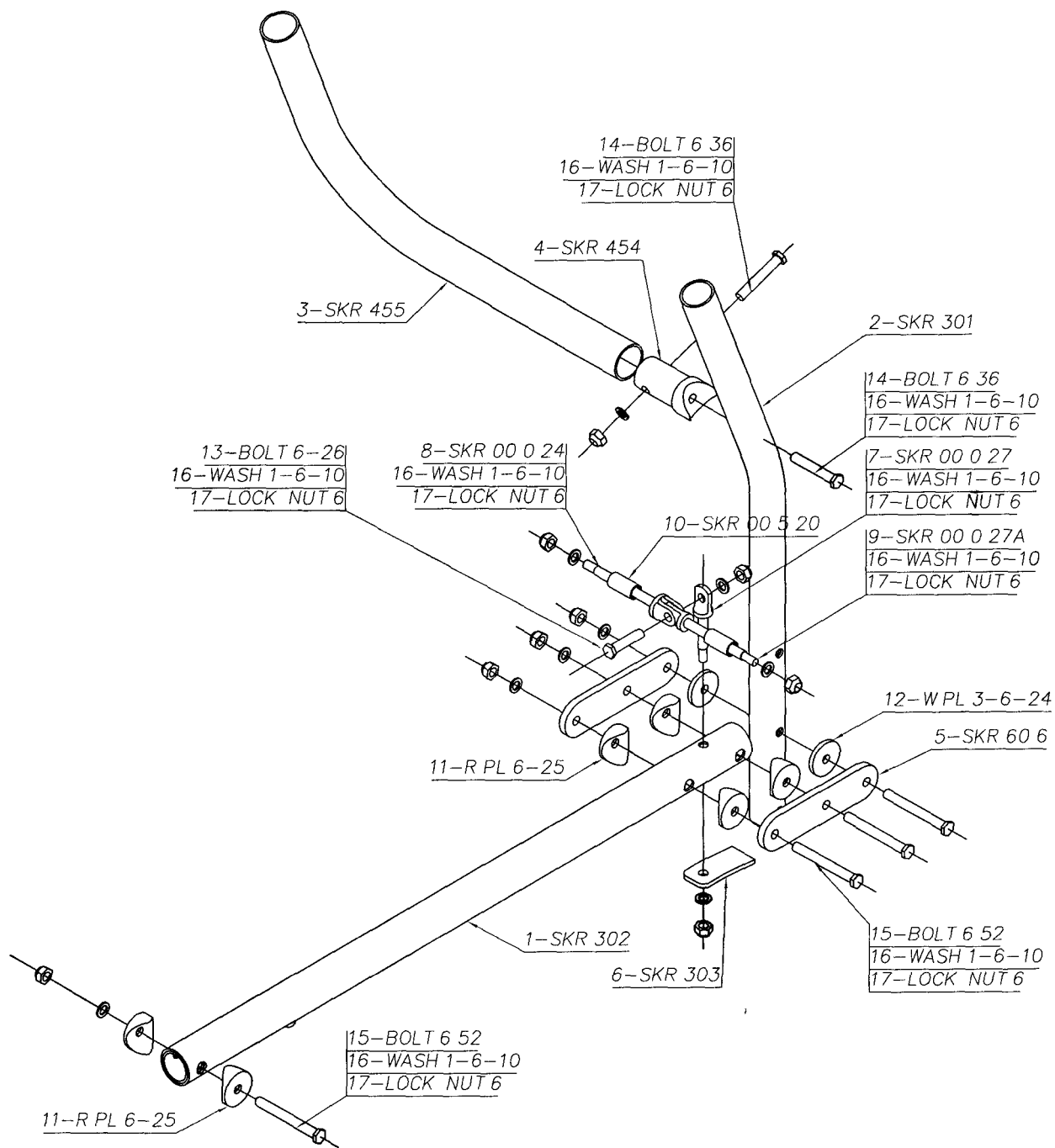

FRONT

SKR. TK.6

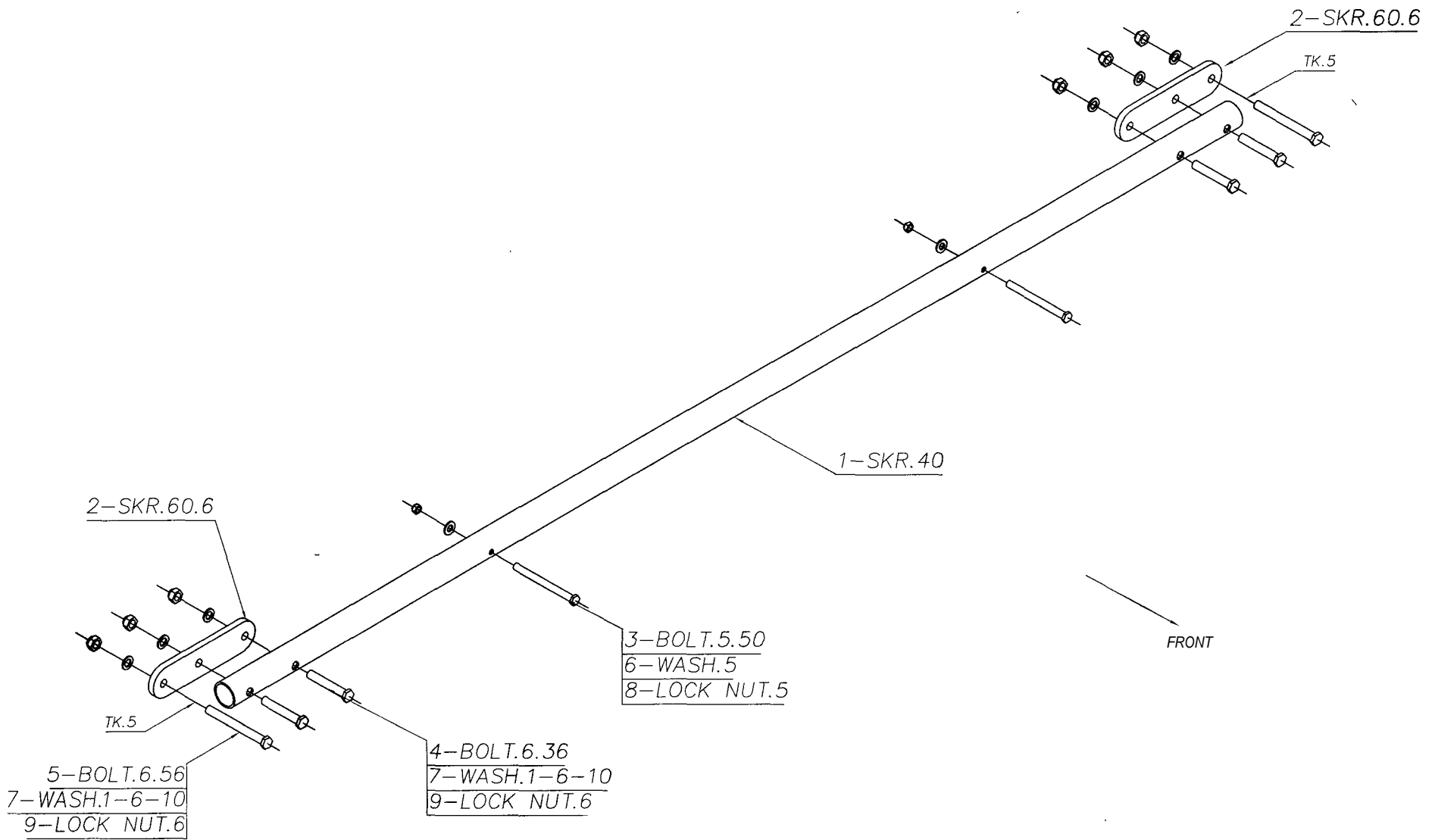

FRONT

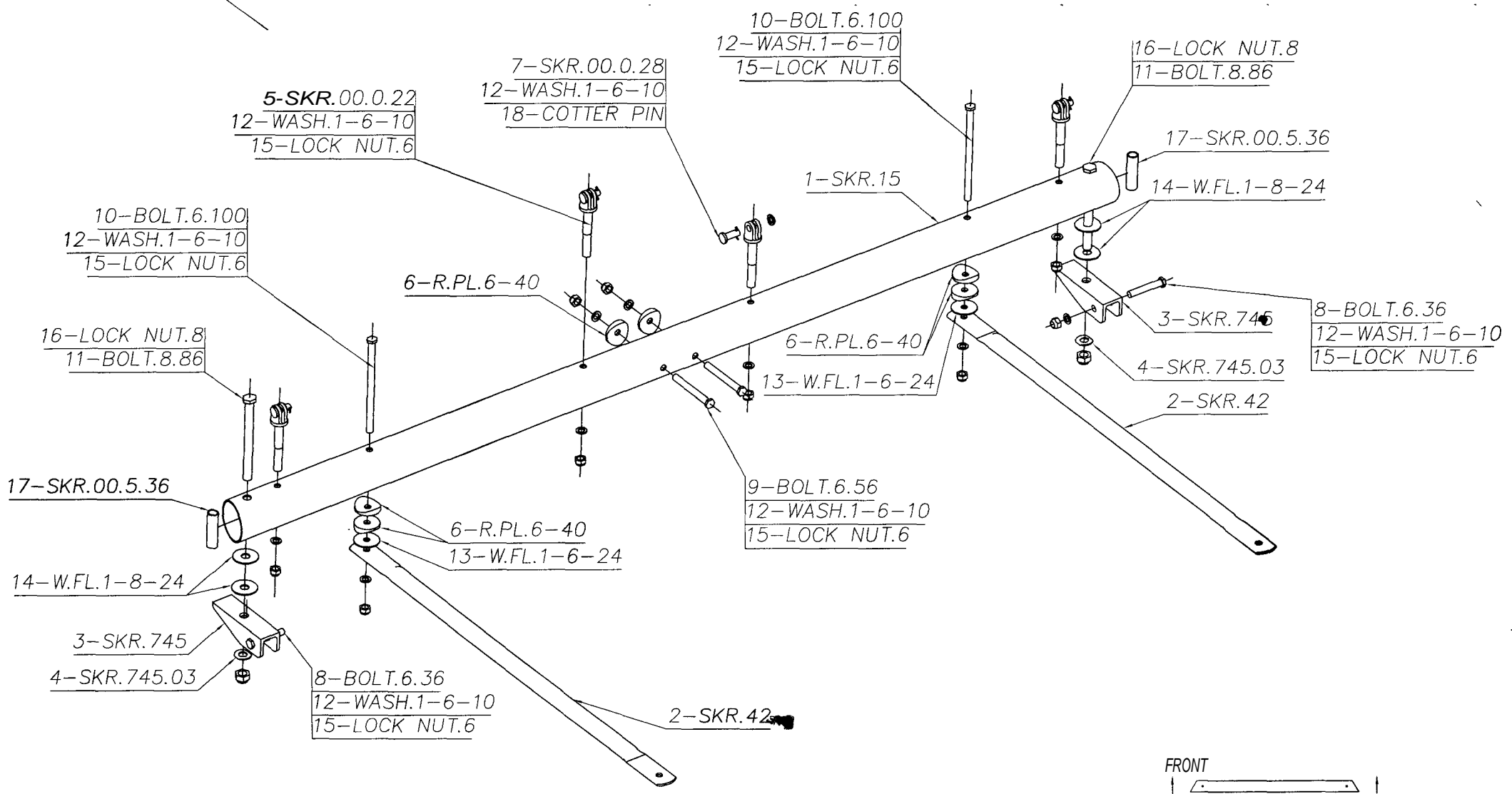

FRONT

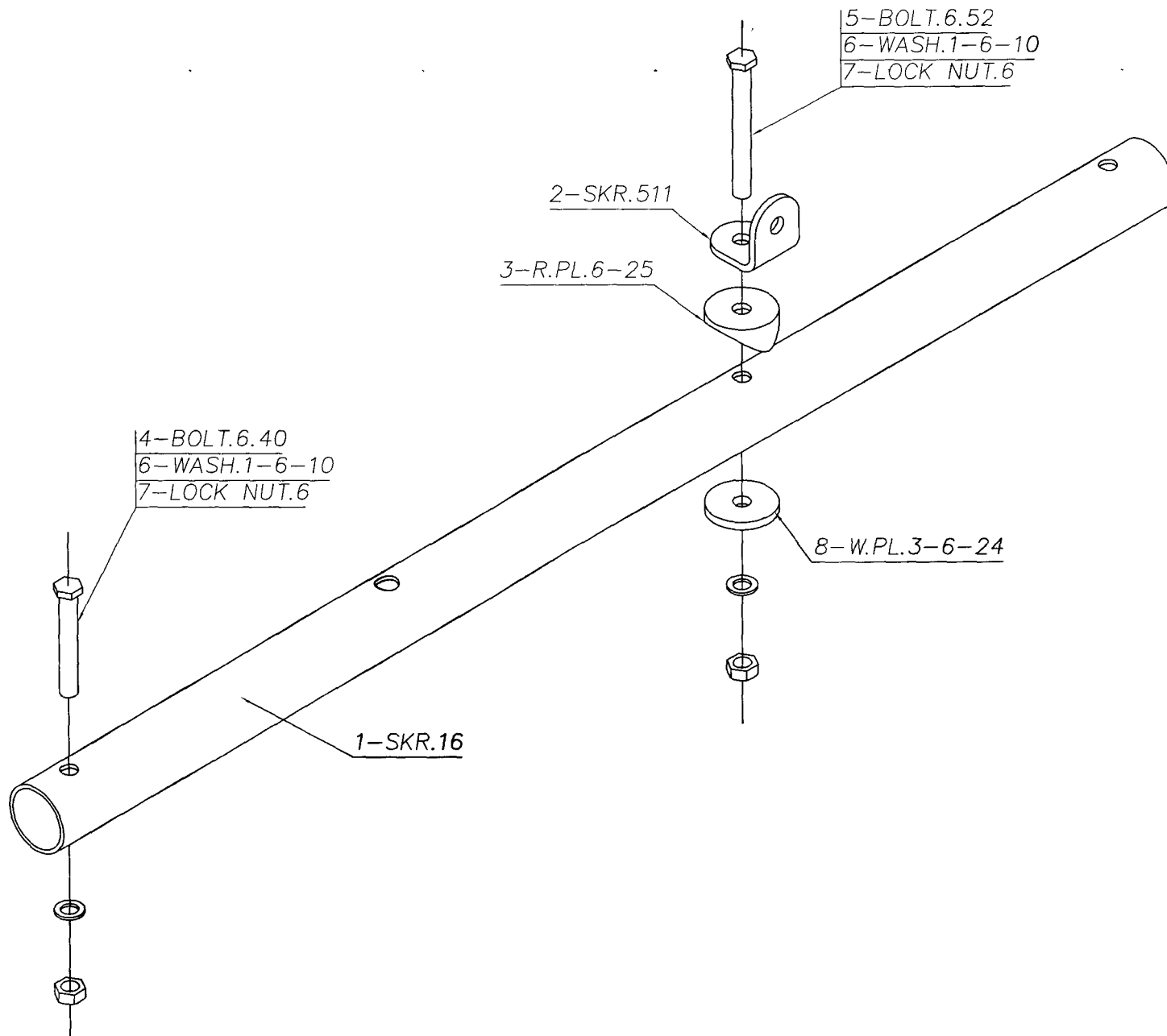

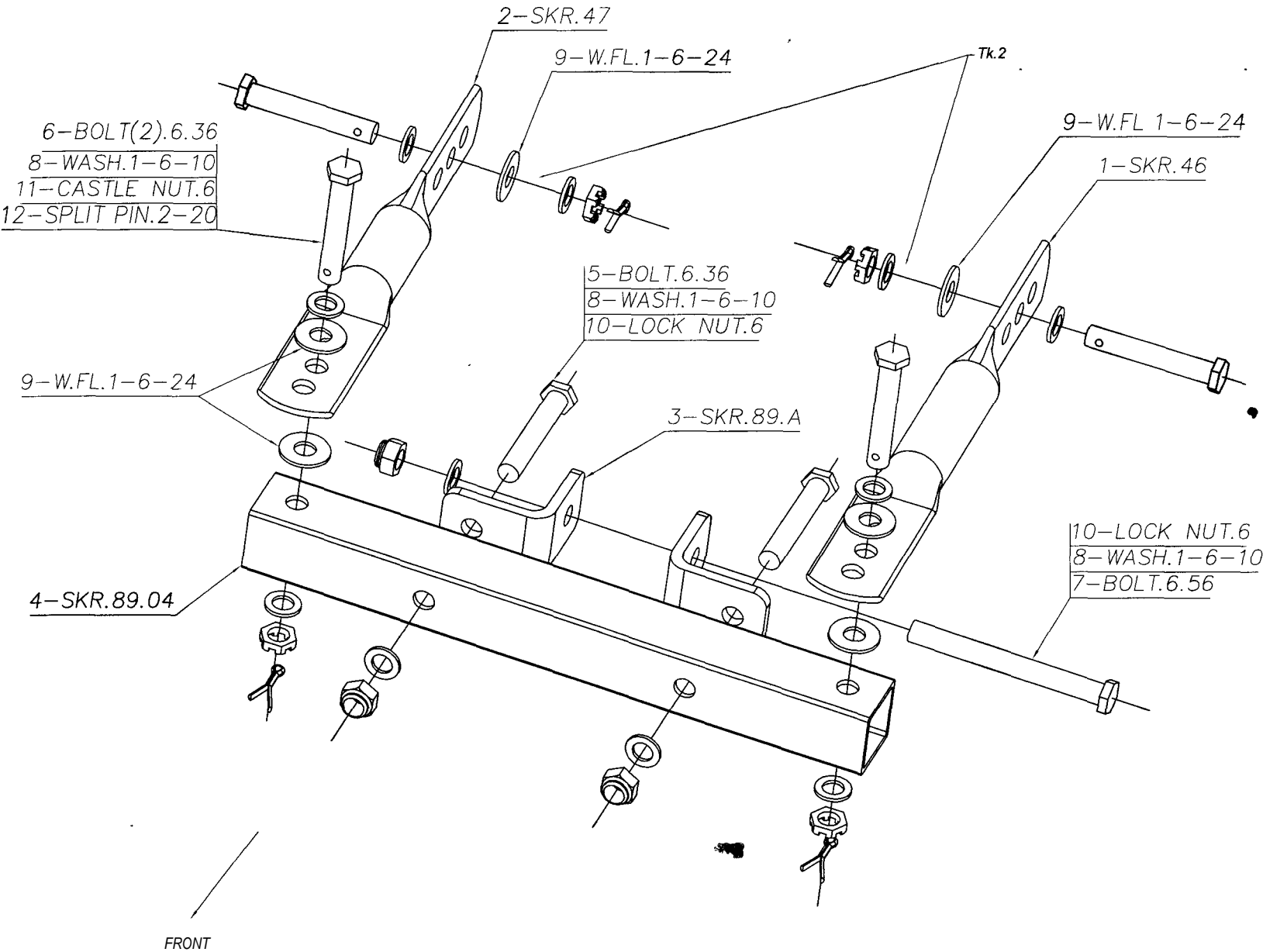

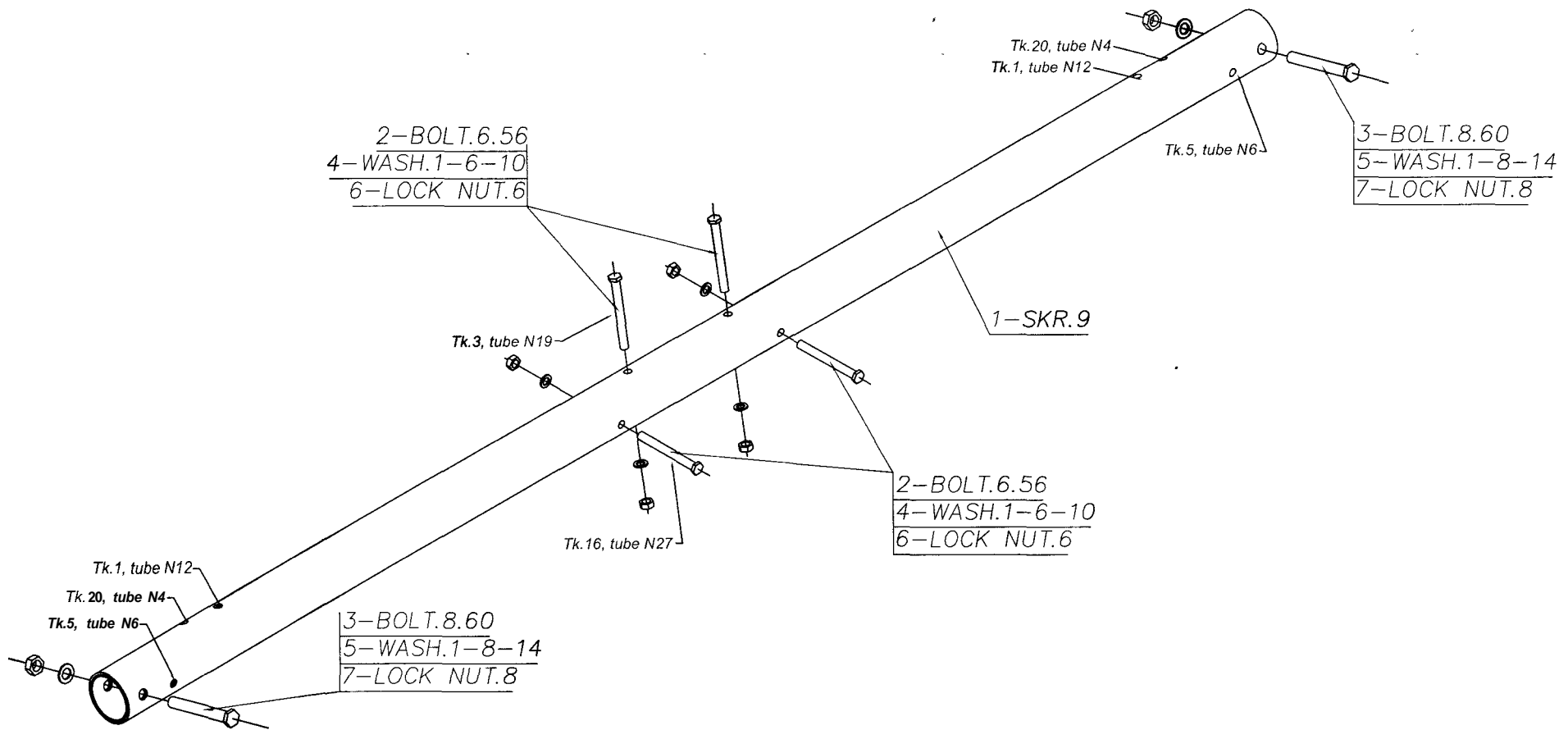

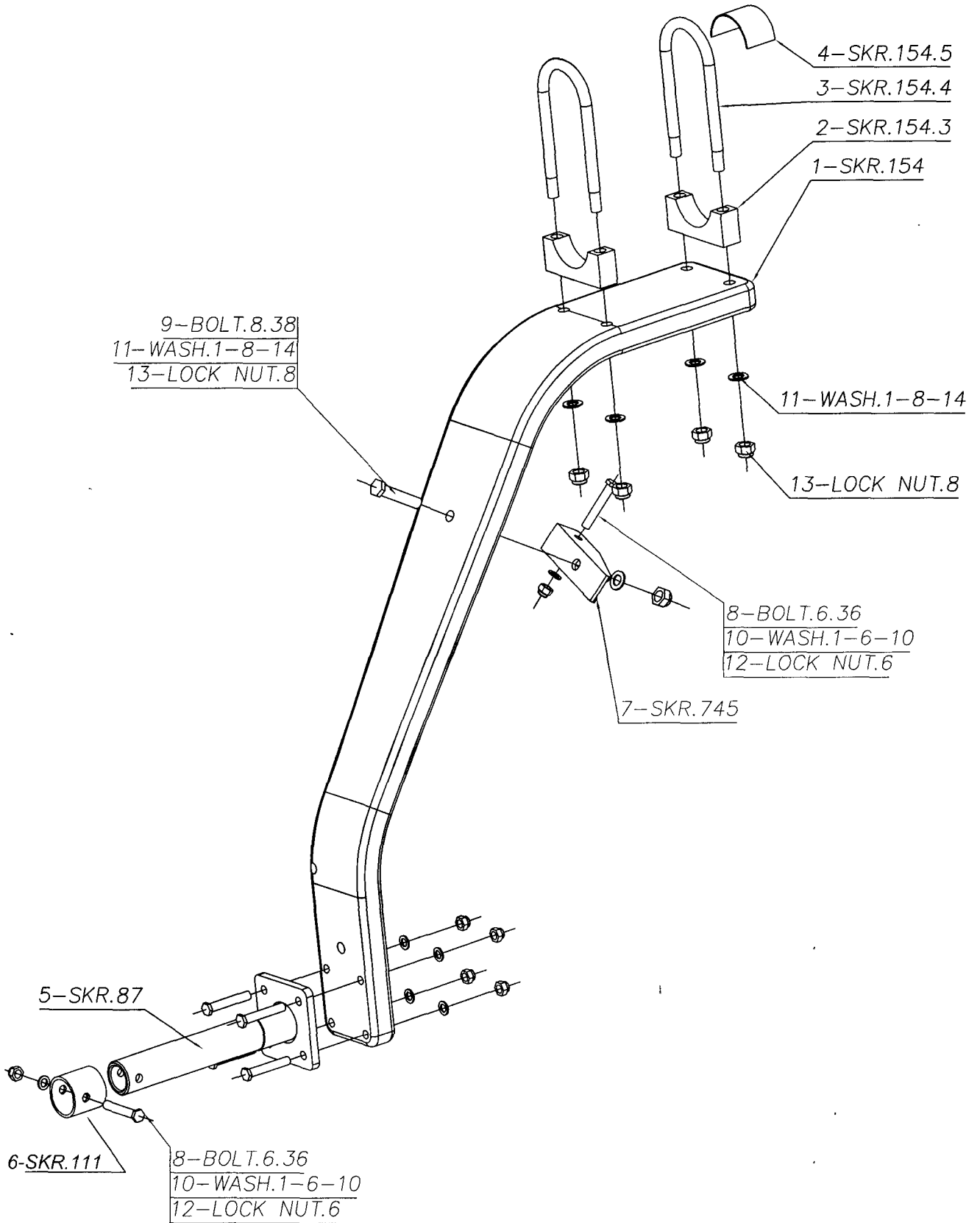

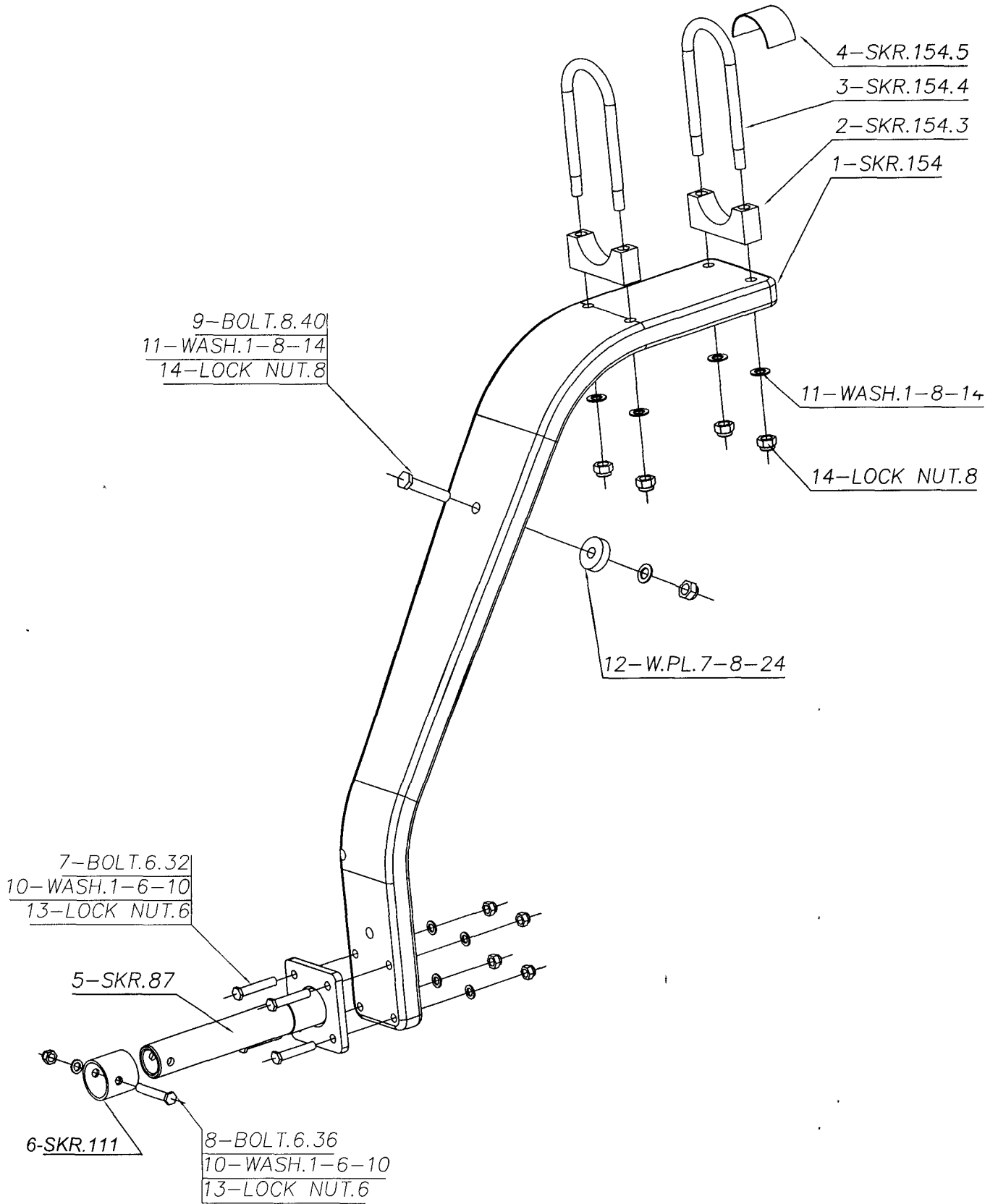

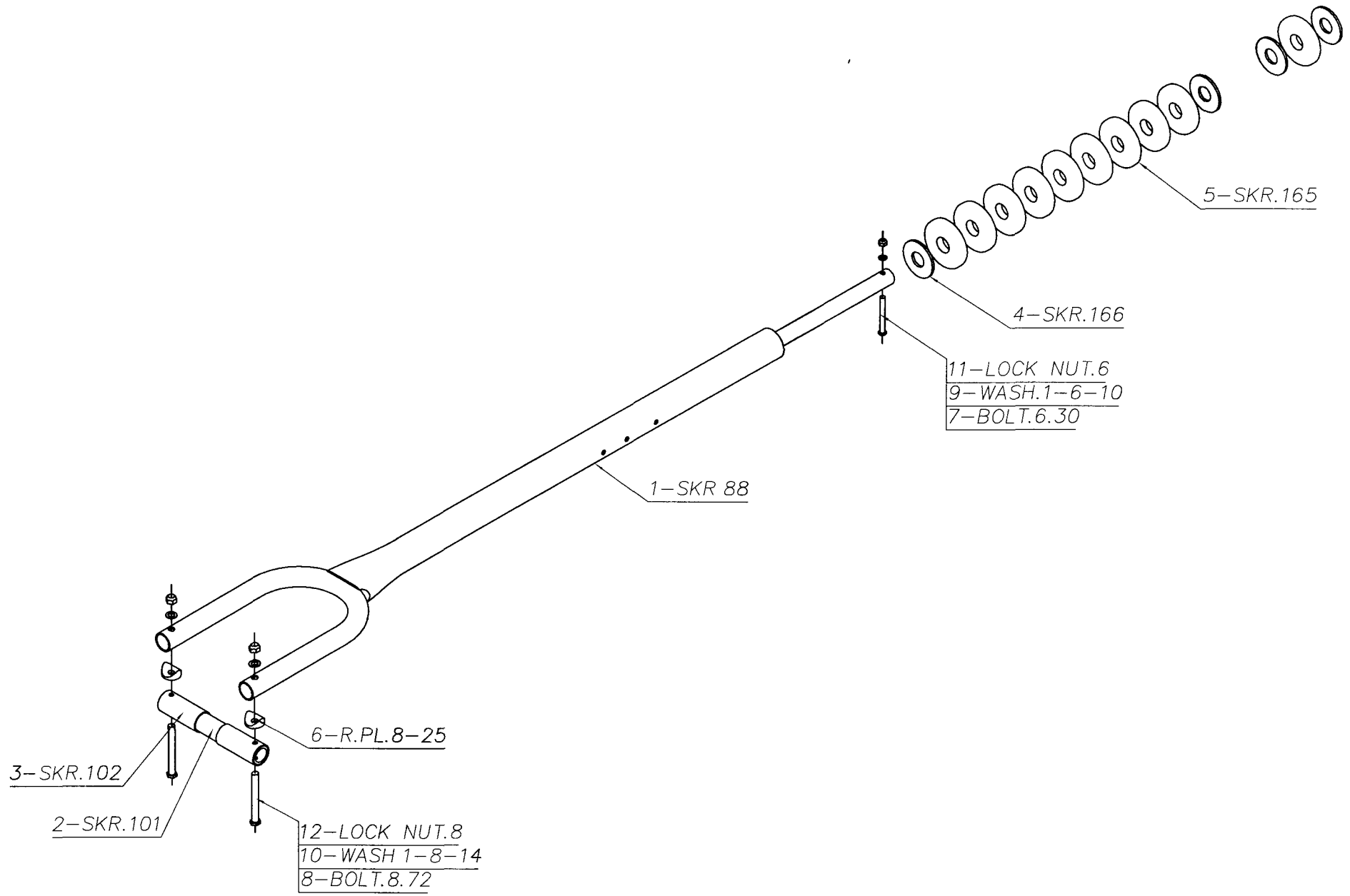

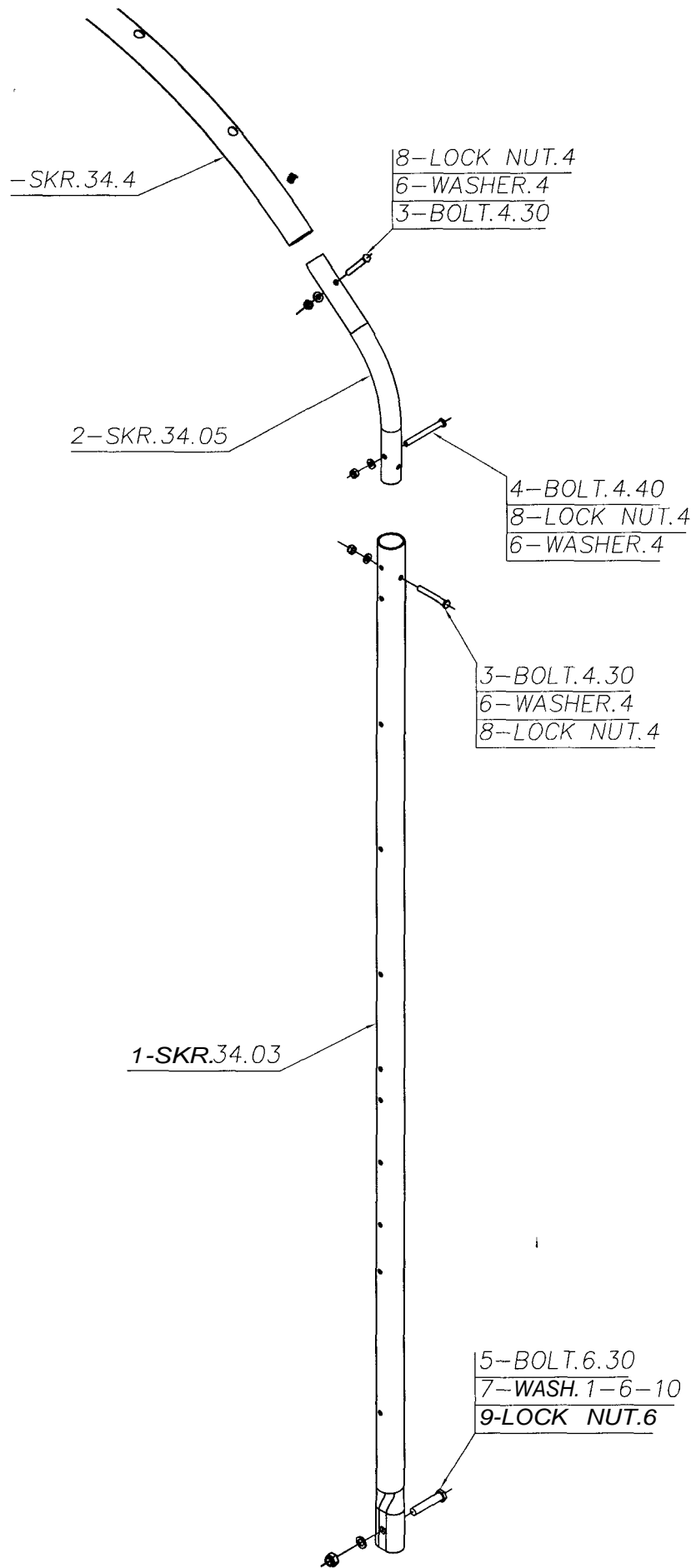

0

SKR. TK. 16

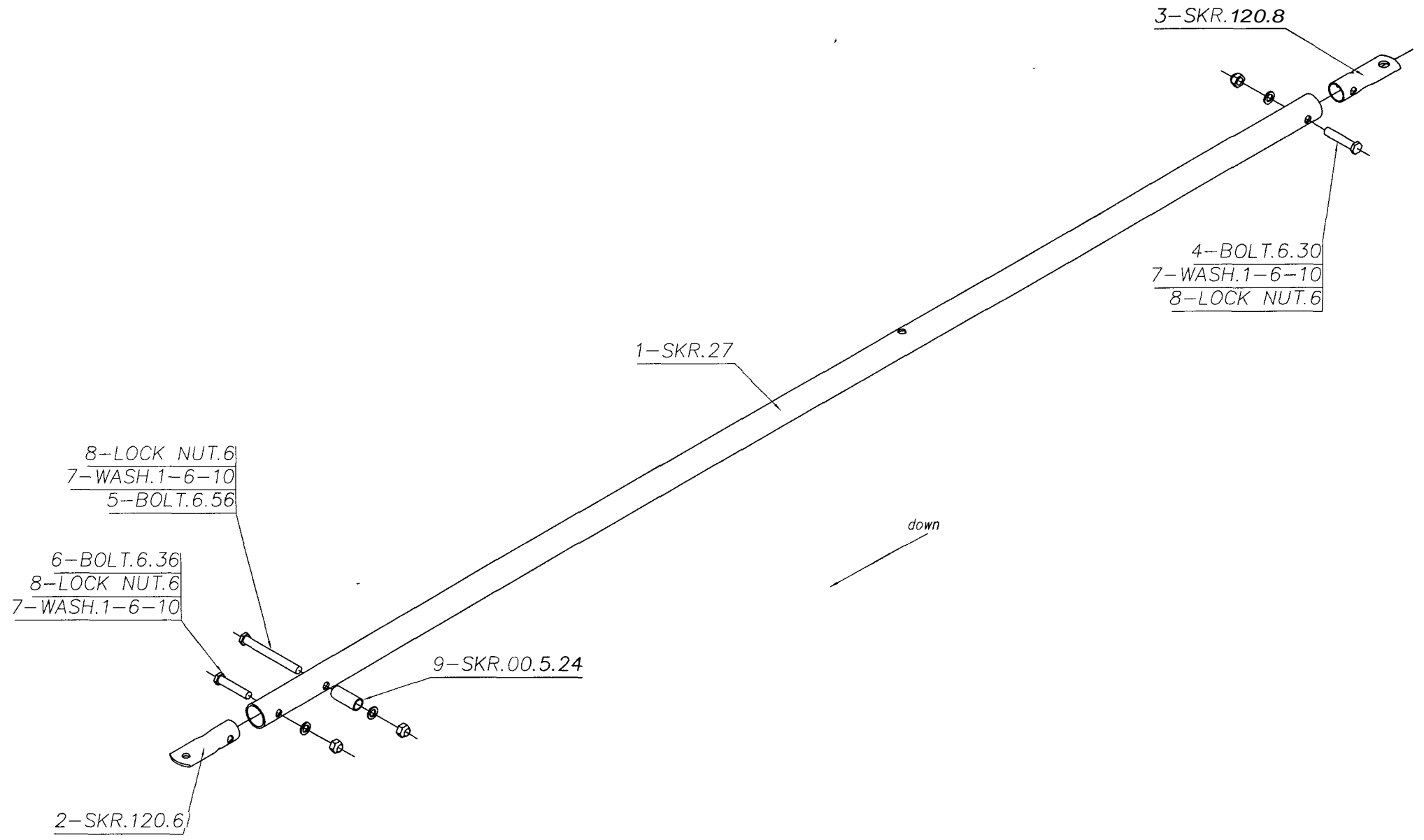

3-SKR.120.8

4-BOLT.6.30
7-WASH.1-6-10
8-LOCK NUT.6

1-SKR.27

down

9-SKR.00.5.24

8-LOCK NUT.6
7-WASH.1-6-10
5-BOLT.6.56

6-BOLT.6.36
8-LOCK NUT.6
7-WASH.1-6-10

2-SKR.120.6

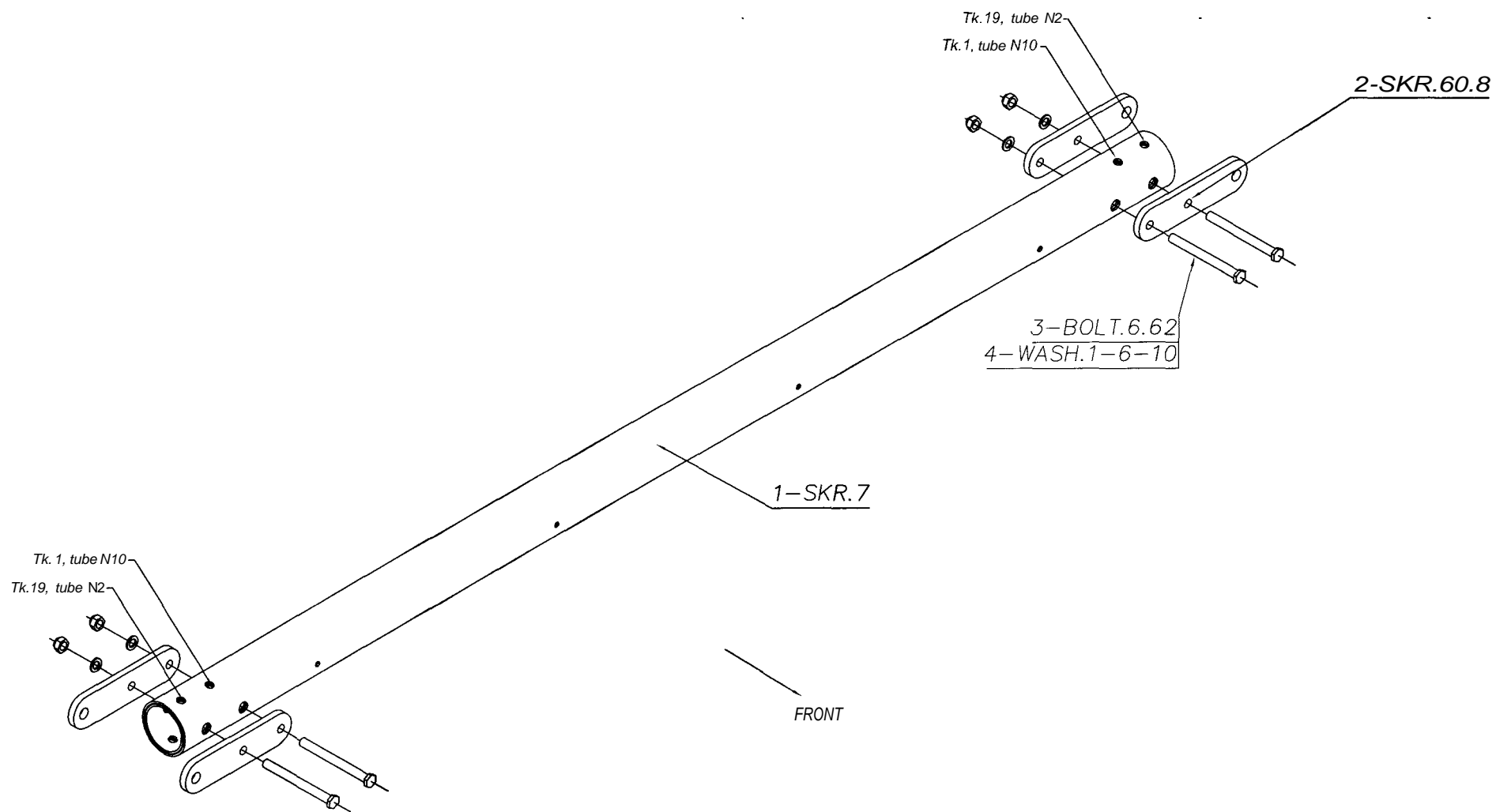

1-SKR.34.4

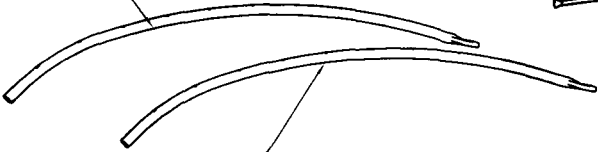

1-SKR.34.4

4-SKR.193.4



5-SKR.193.3



5-SKR.193.3

3-SKR.194.3

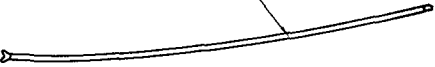

2-SKR.194.4



3-SKR.194.3



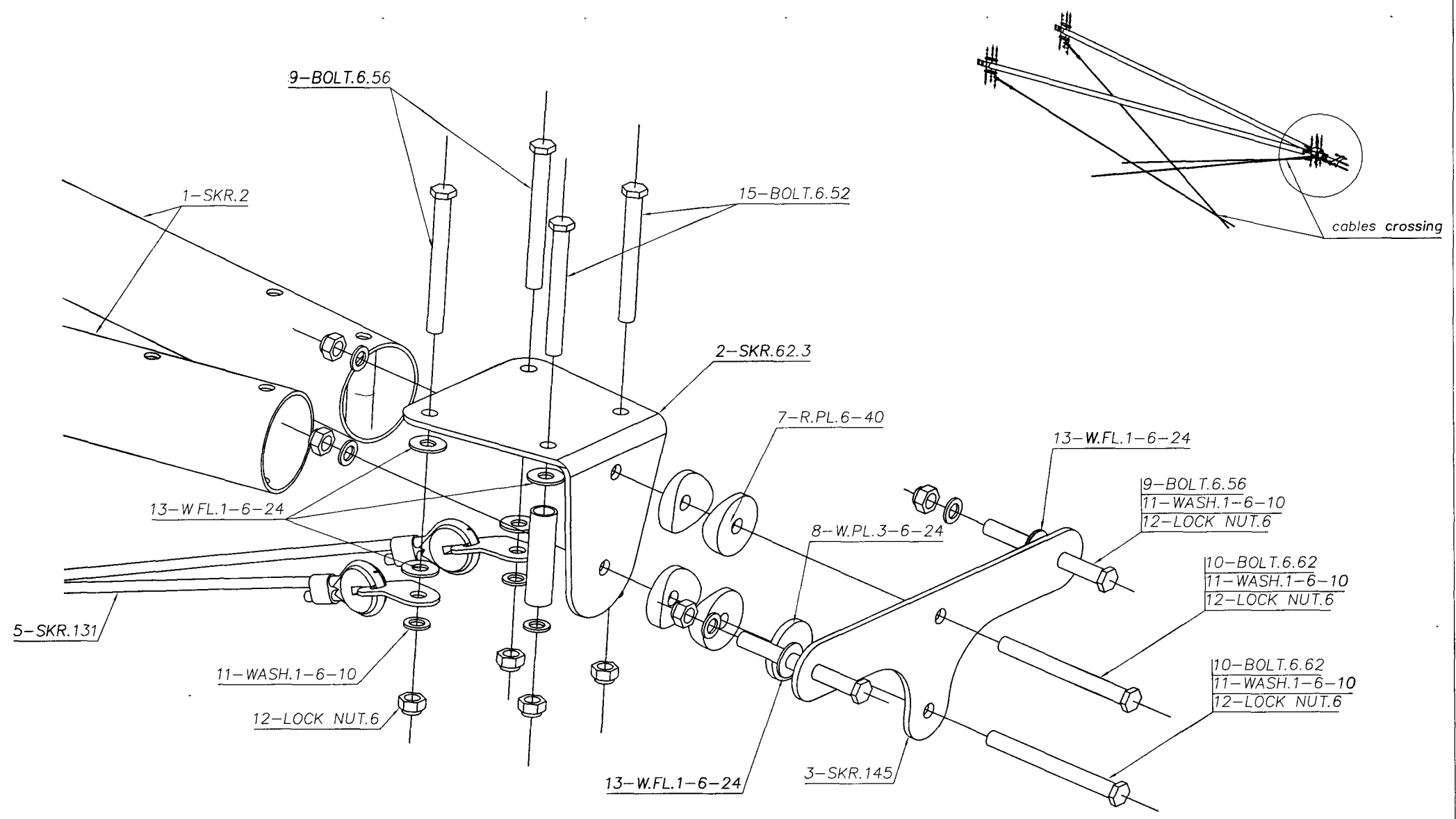

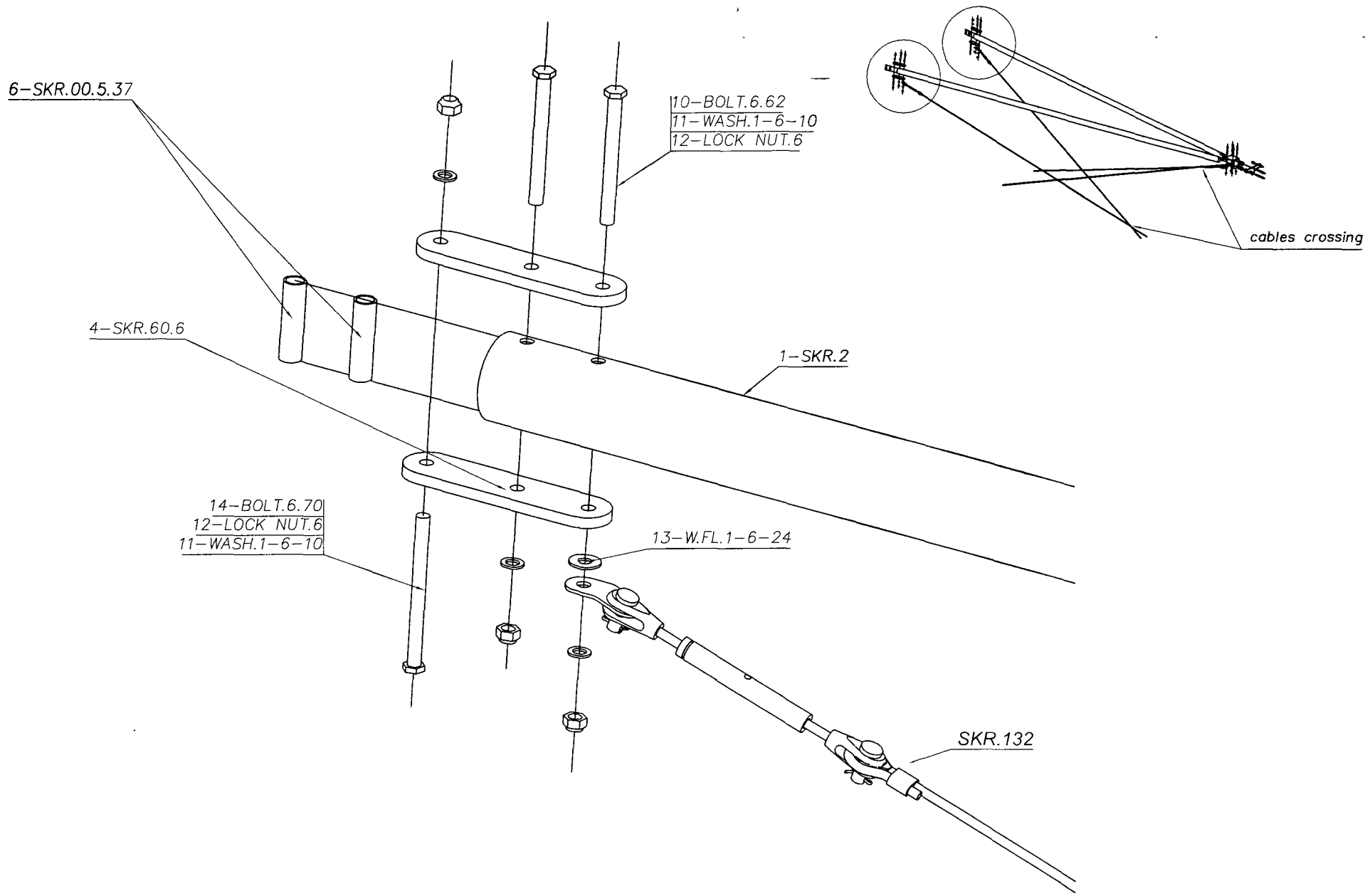

SKR.TK.20/2

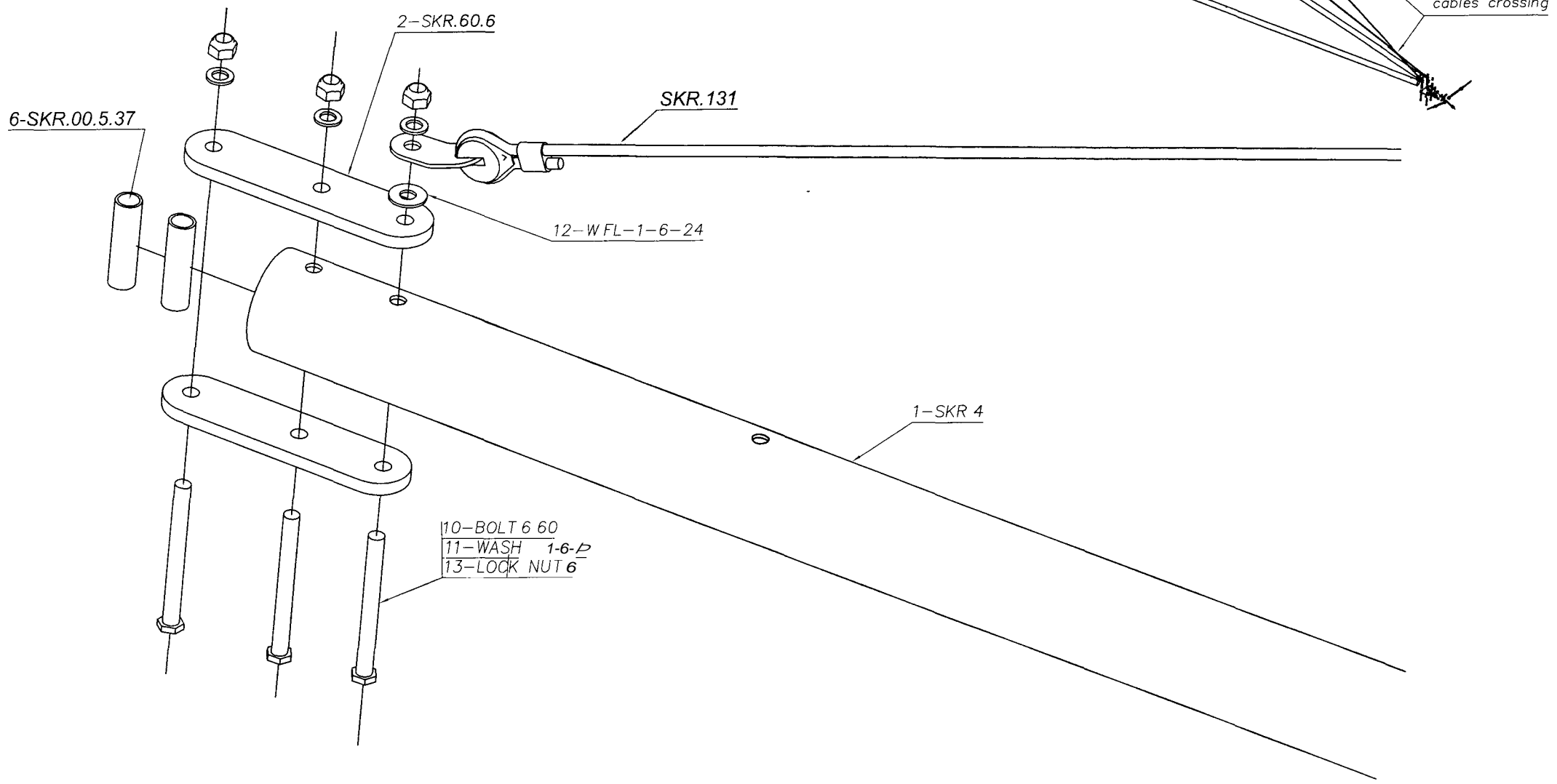

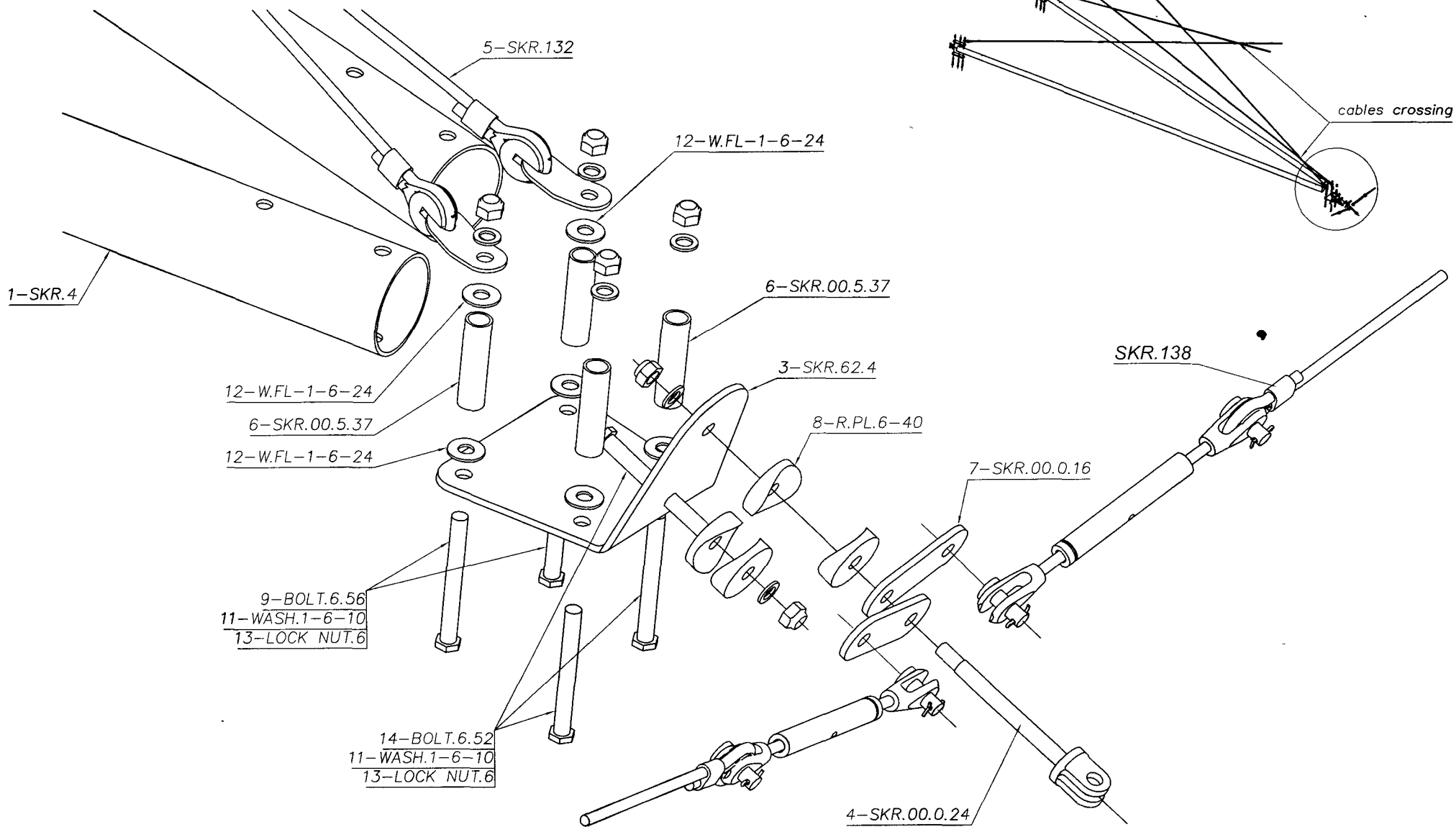

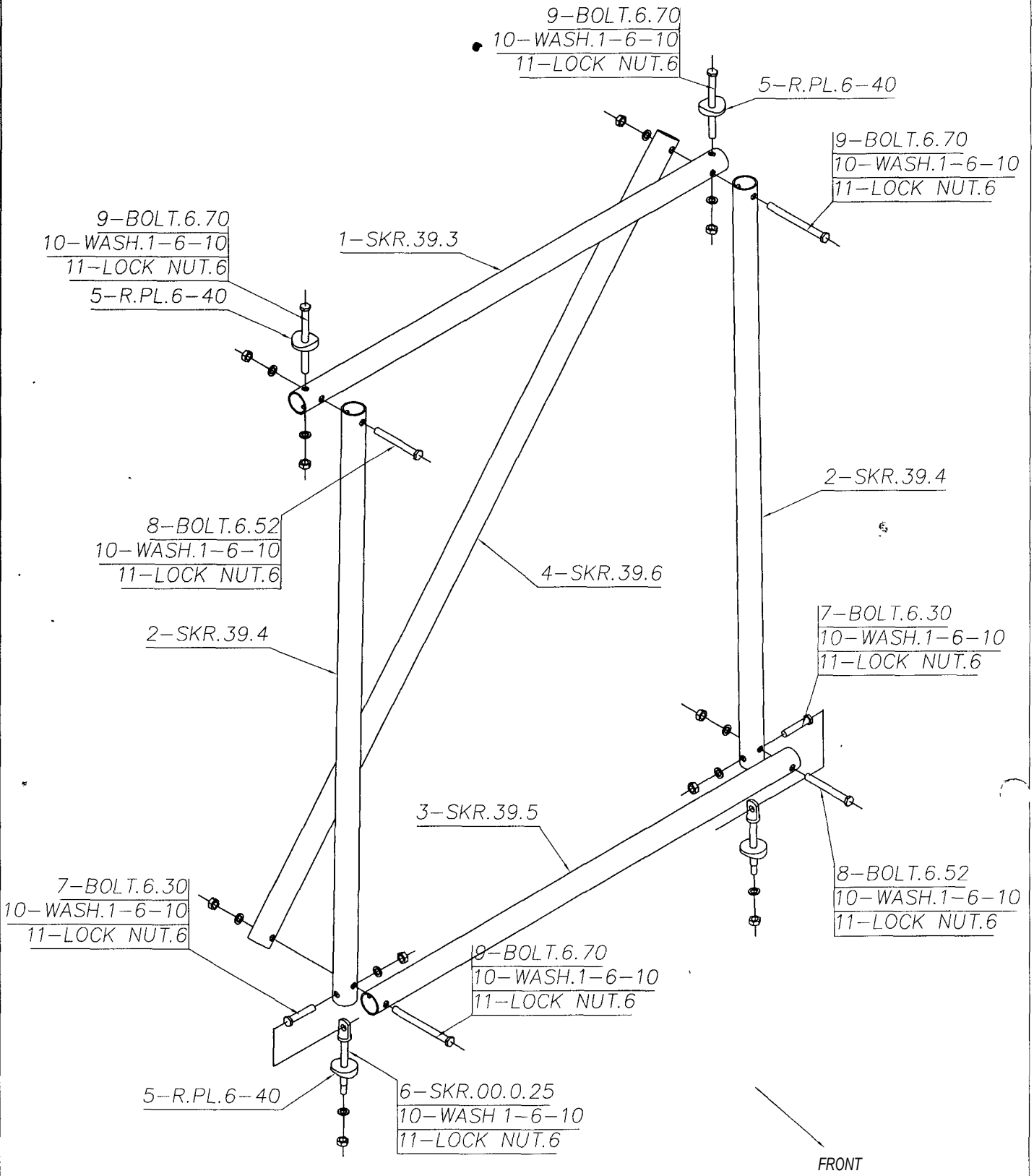

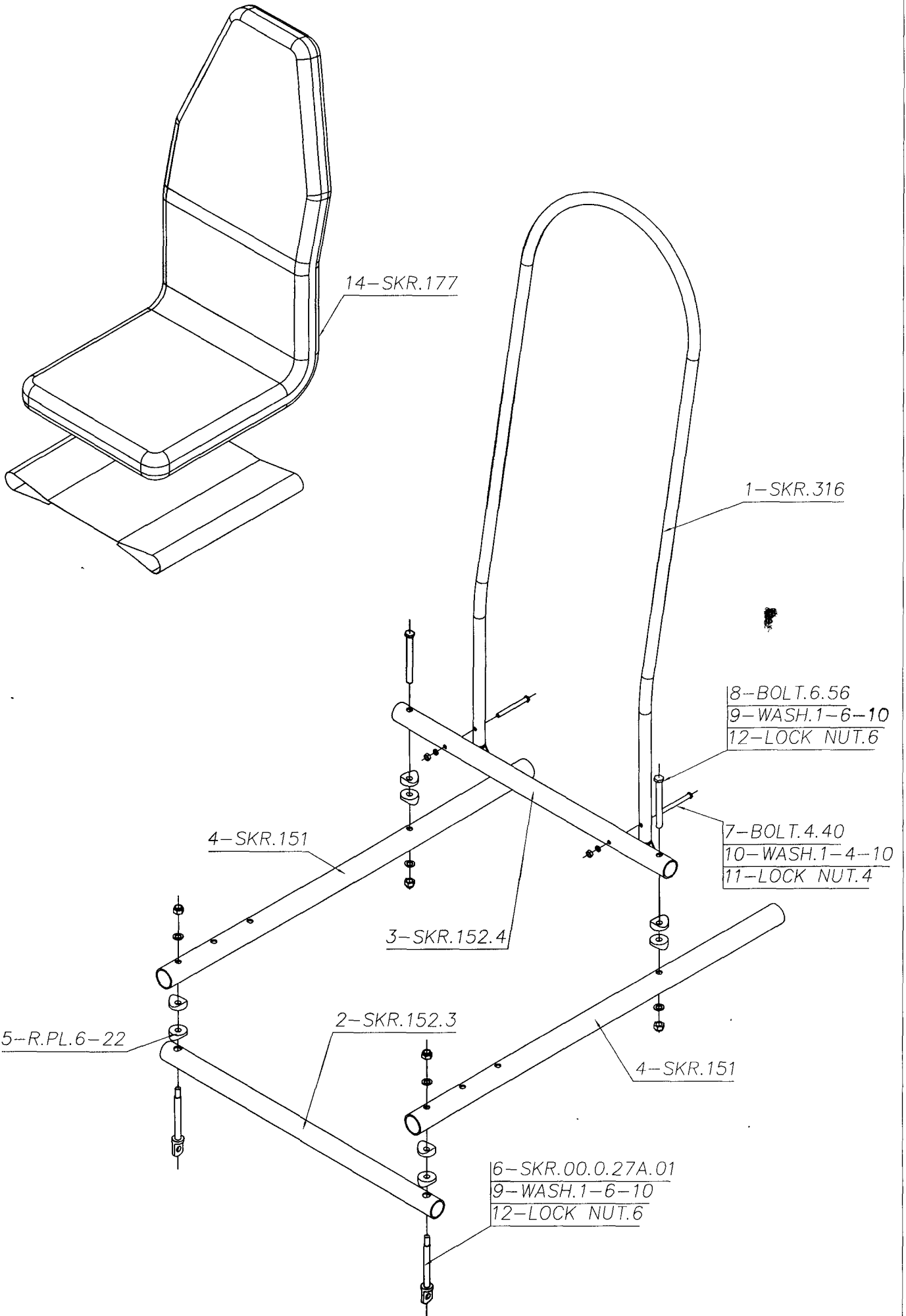

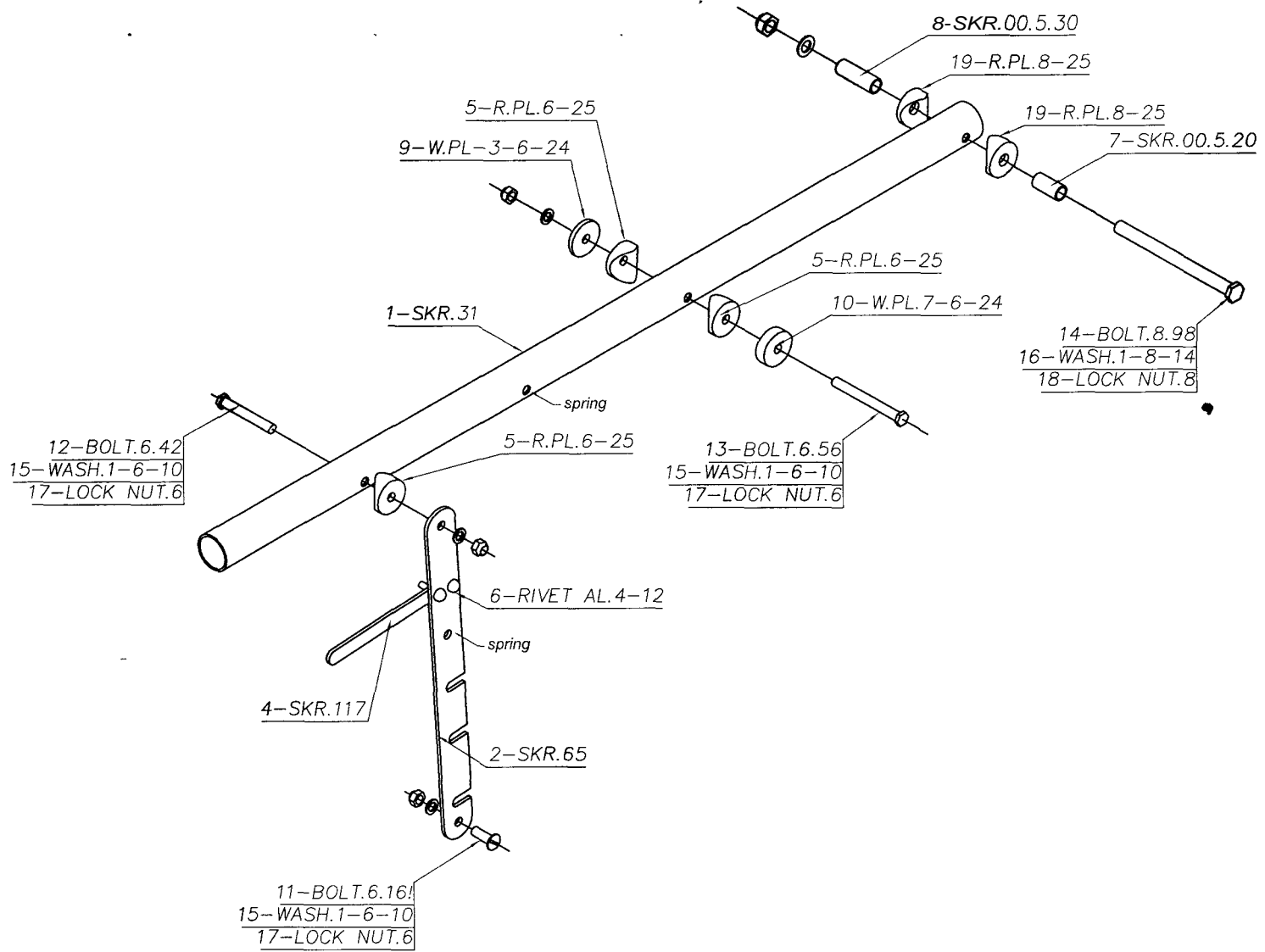

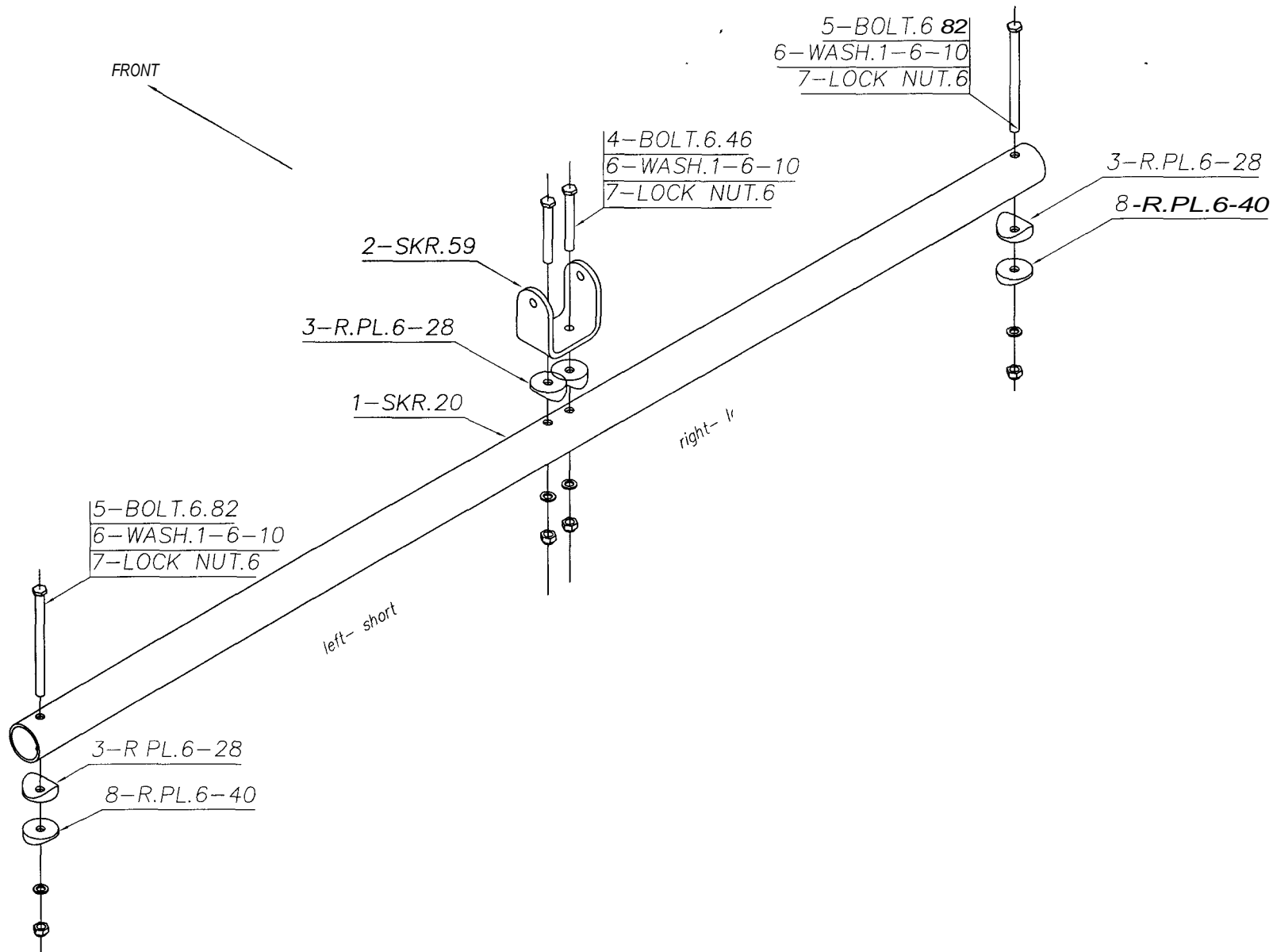

SKR. TK. 26

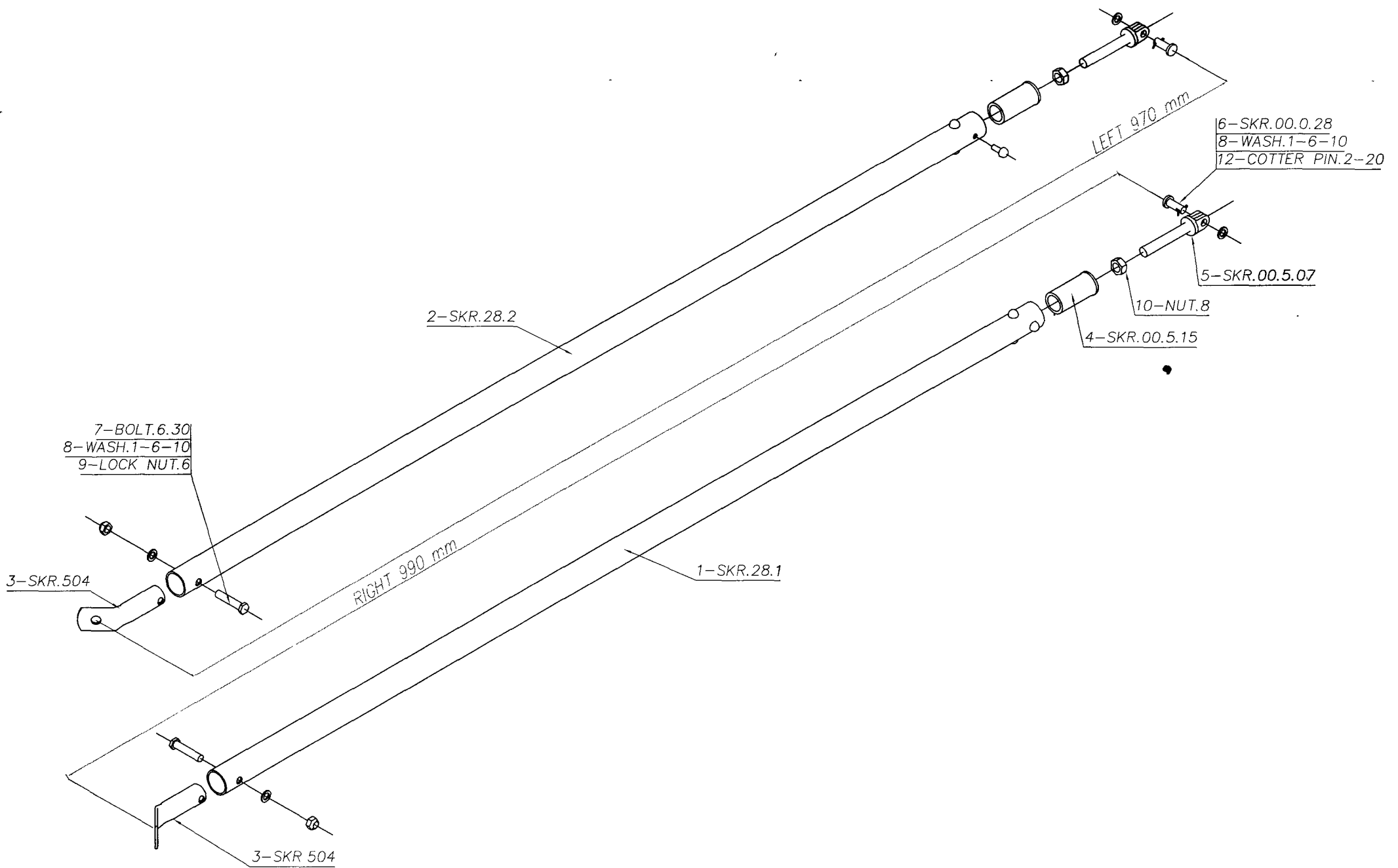

SKR. TK. 27

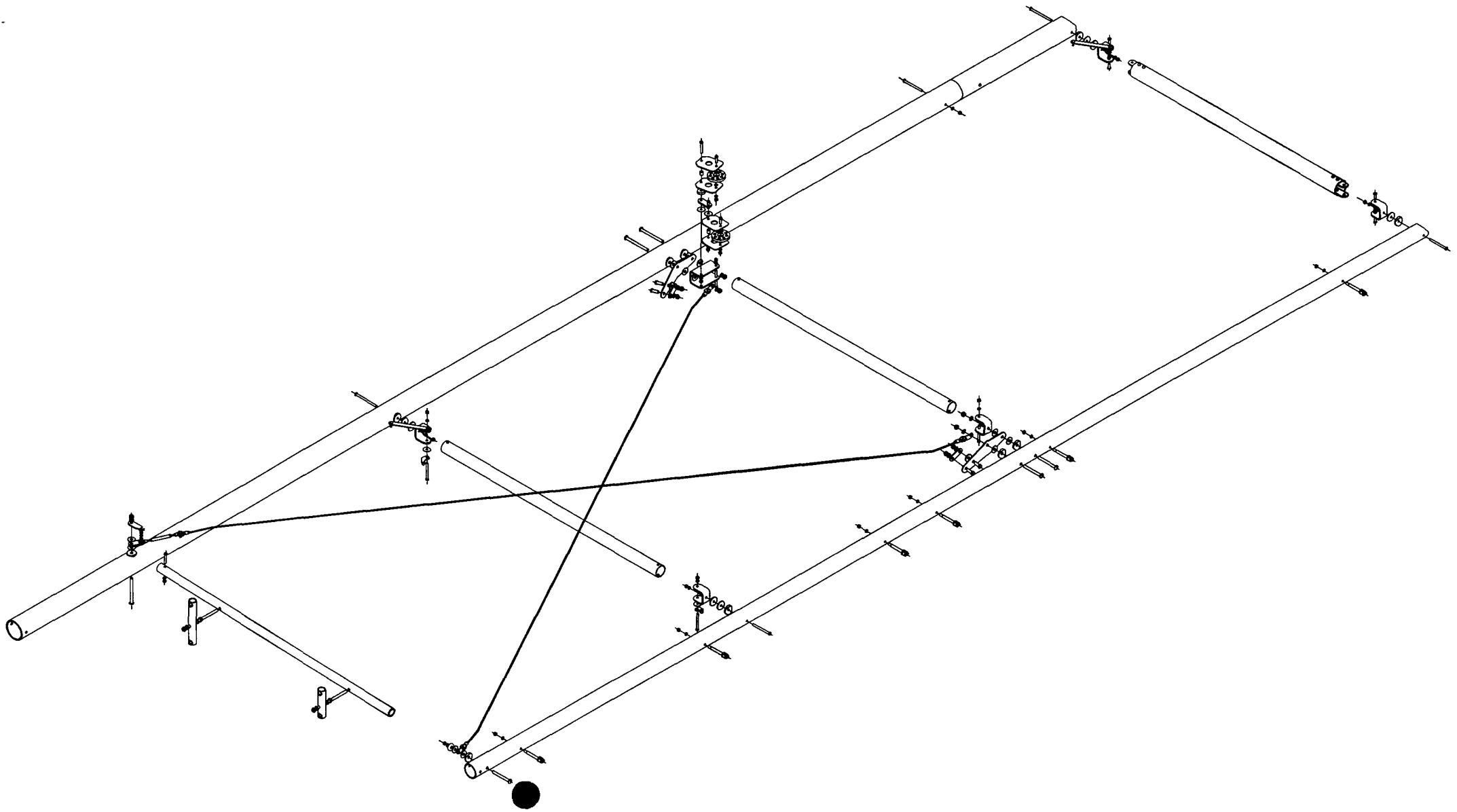

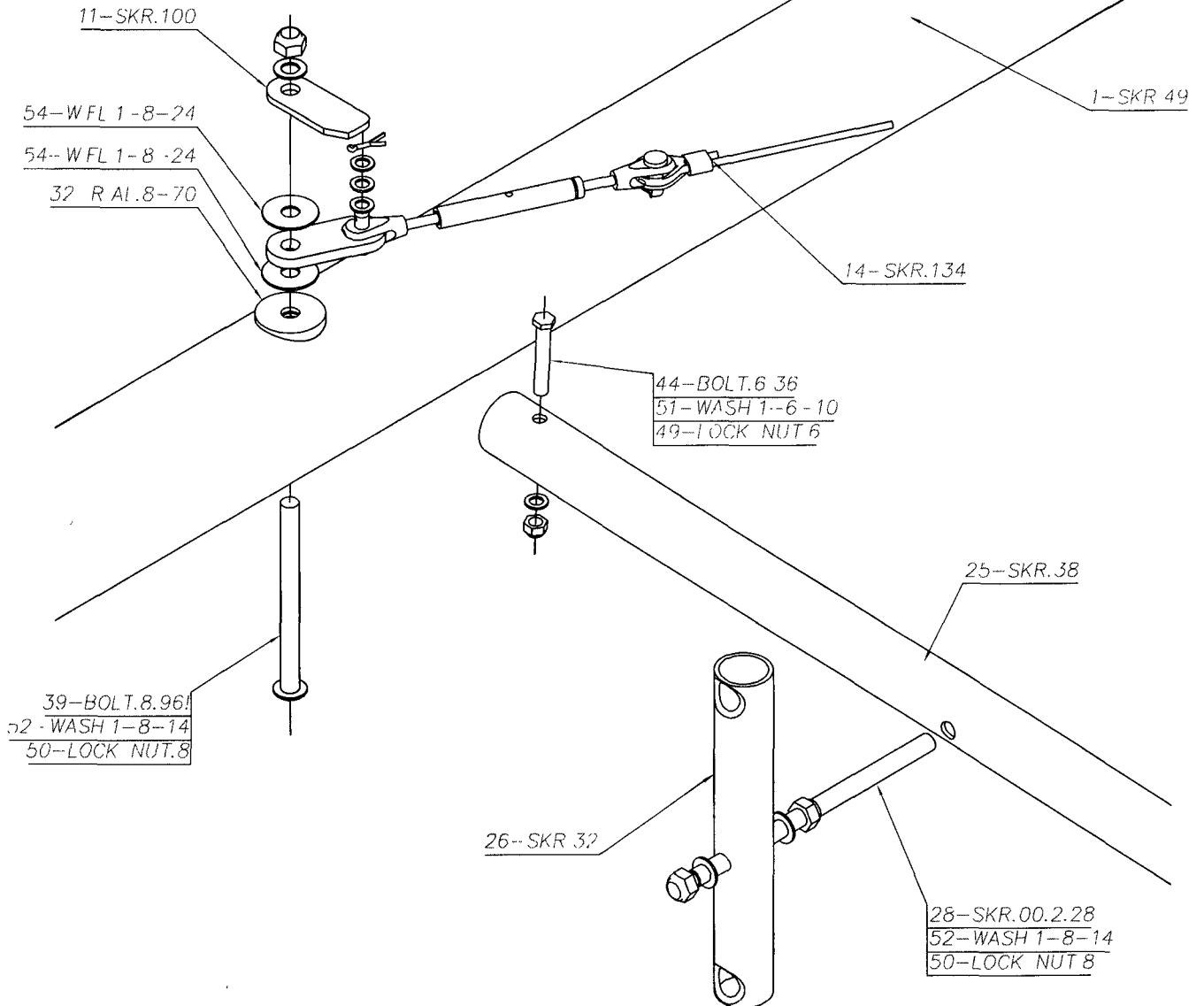
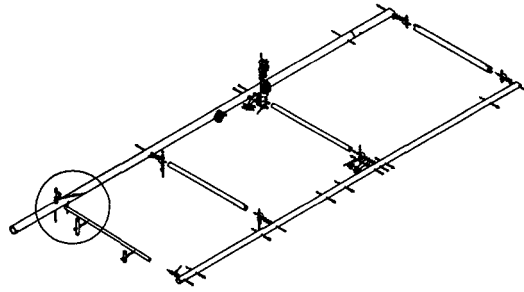

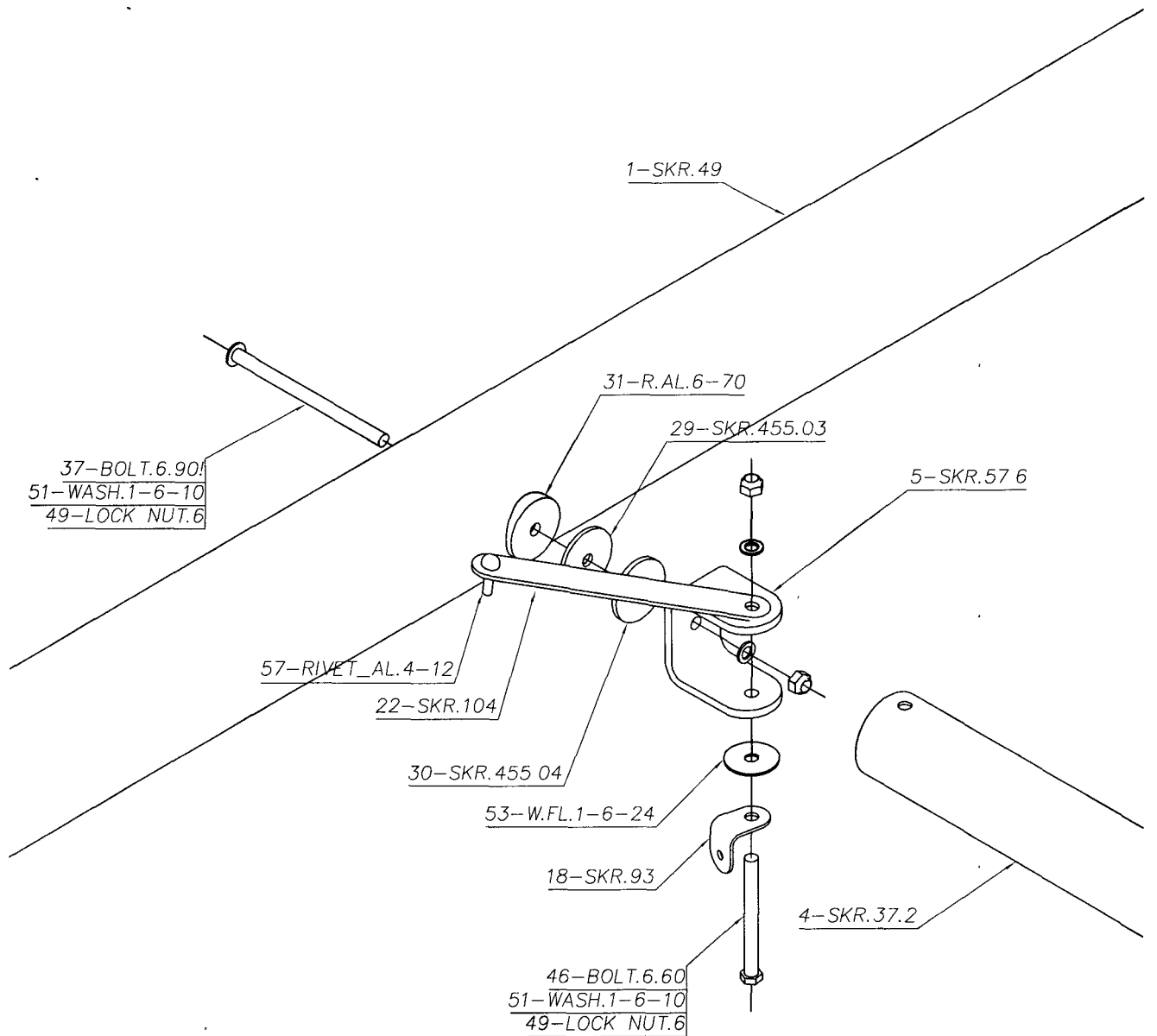
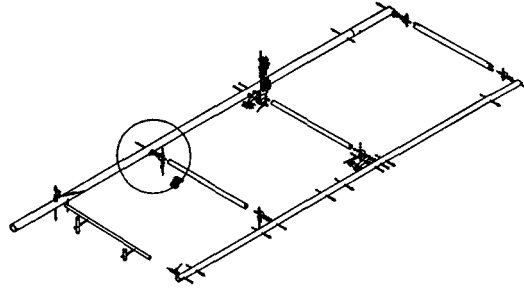

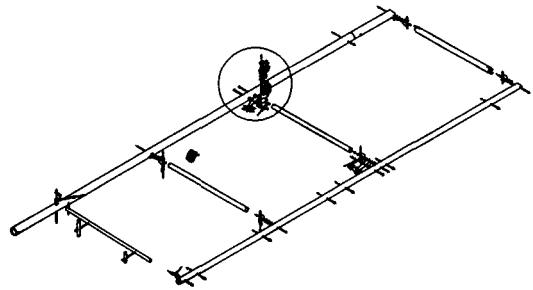

48-BOLT 6 40
49-LOCK NUT 6
51-WASH 1-6-10

42-BOLT 6 20
49-LOCK NUT 6
51-WASH 1-6-10

19-SKR 71

20-SKR 00 5 10

51-WASH 1-6-10

24-SKR 481

51-WASH 1-6-10

55-W PL 7-6-24

43-BOLT 6 24
49-LOCK NUT 6
51-WASH 1-6-10

23-SKR 00 2 26

53-W FL 1-6-24

42-BOLT 6 20
49-LOCK NUT 6
51-WASH 1-6-10

39-BOLT 8 96
50-LOCK NUT 8
52-WASH 1-8-14

20-SKR 00 5 10

51-WASH 1-6-10

24-SKR 481

51-WASH 1-6-10

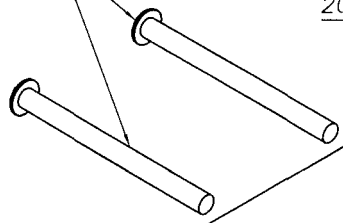

32-R AL 8-70

54-W FL 1-8-24

7-SKR 58

46-BOLT 6 60
49-LOCK NUT 6
51-WASH 1-6-10

50-LOCK NUT 8
52-WASH 1-8-14
47-BOLT 8 22

1-SKR 49

8-SKR 82 2 02

56-W PL 3-8-24

10-SKR 506

54-W FL 1-8-24

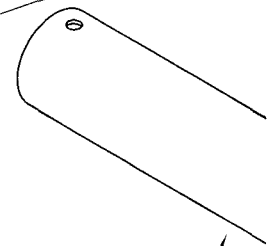

4-SKR 37 2

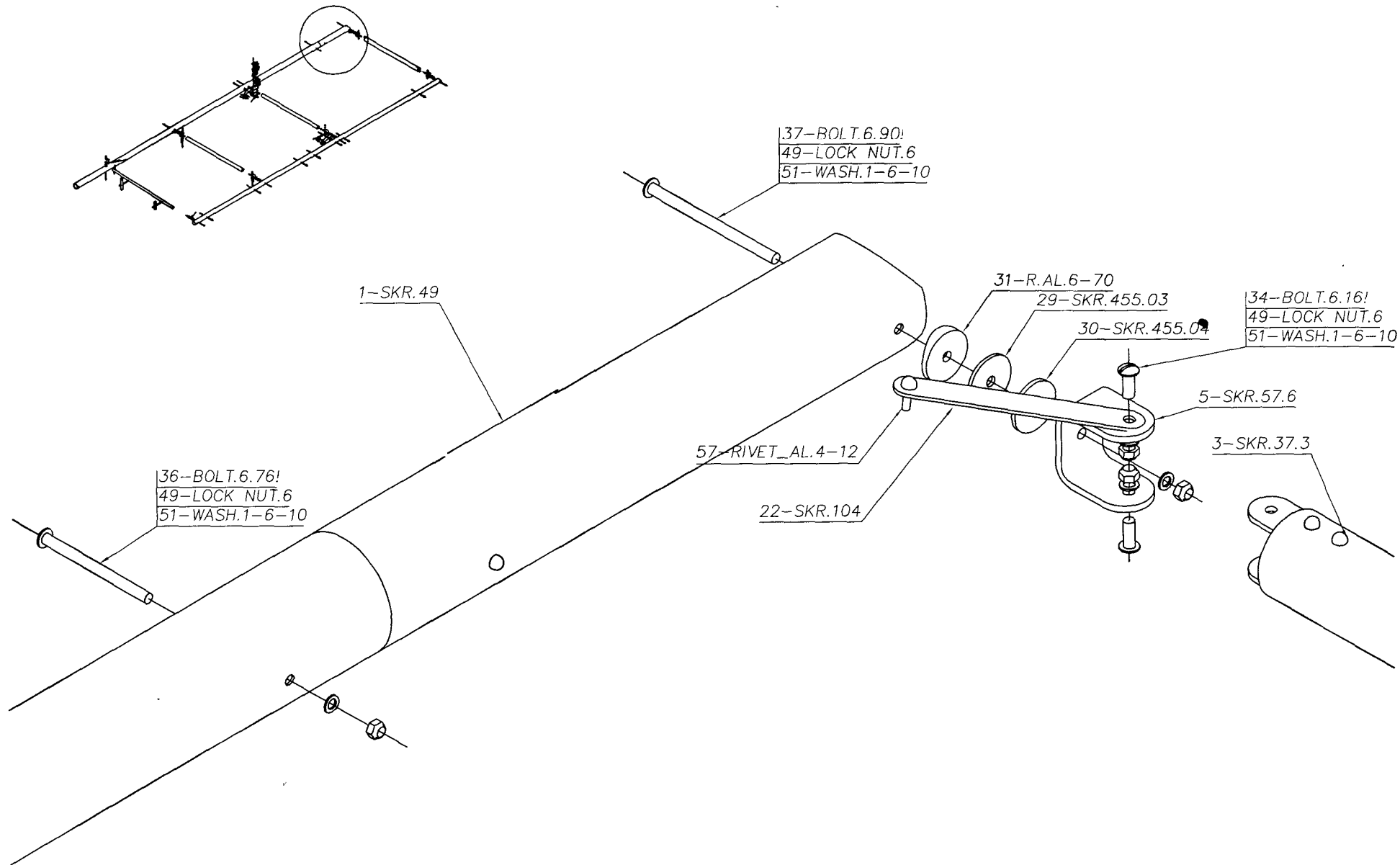

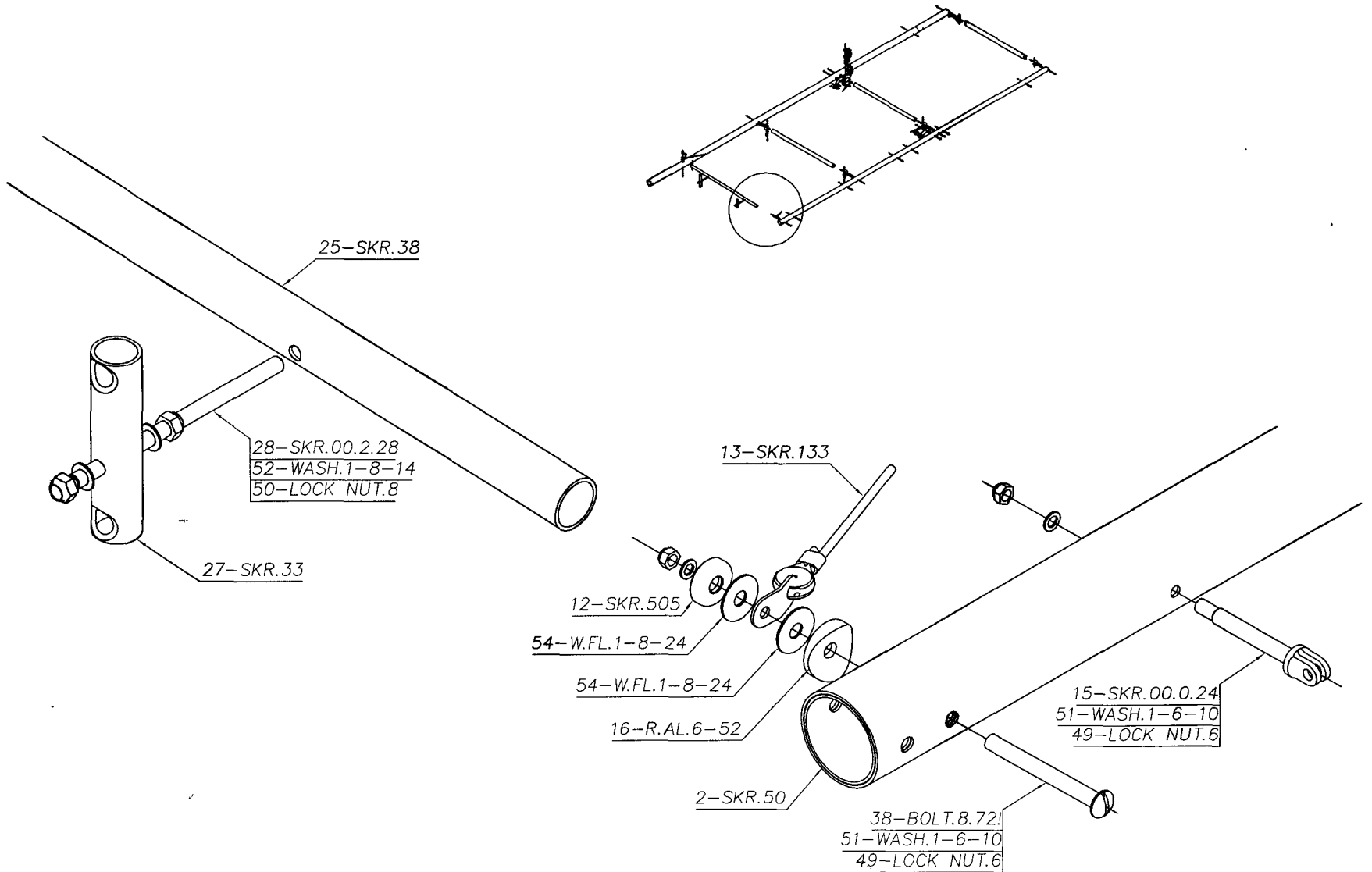

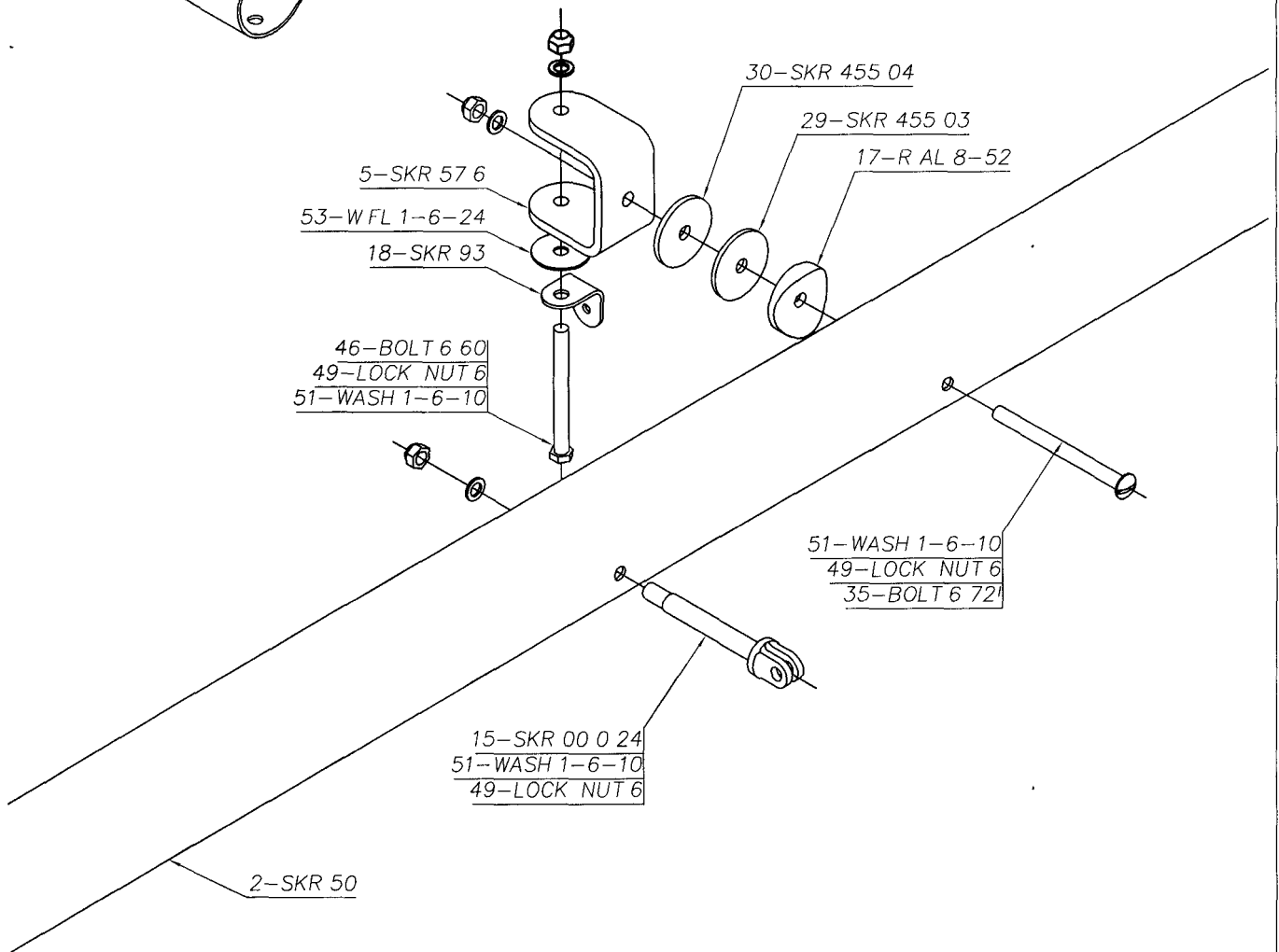
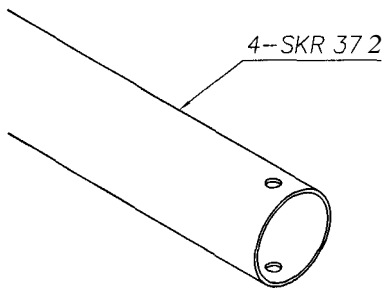
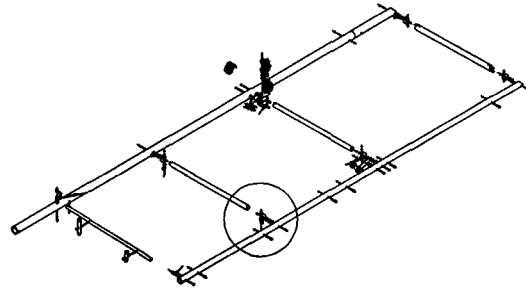

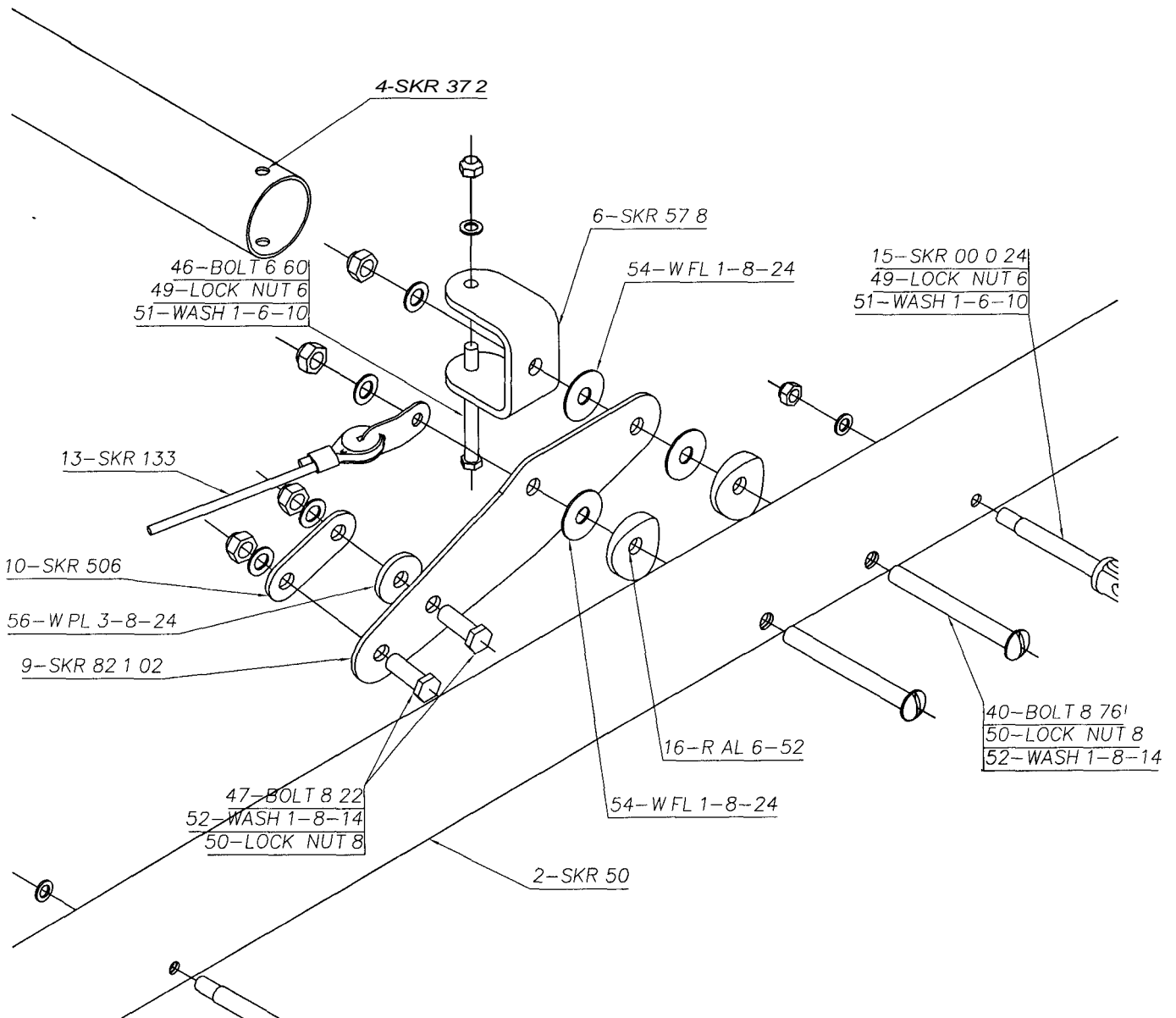
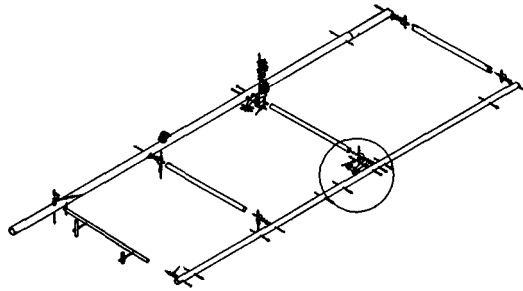

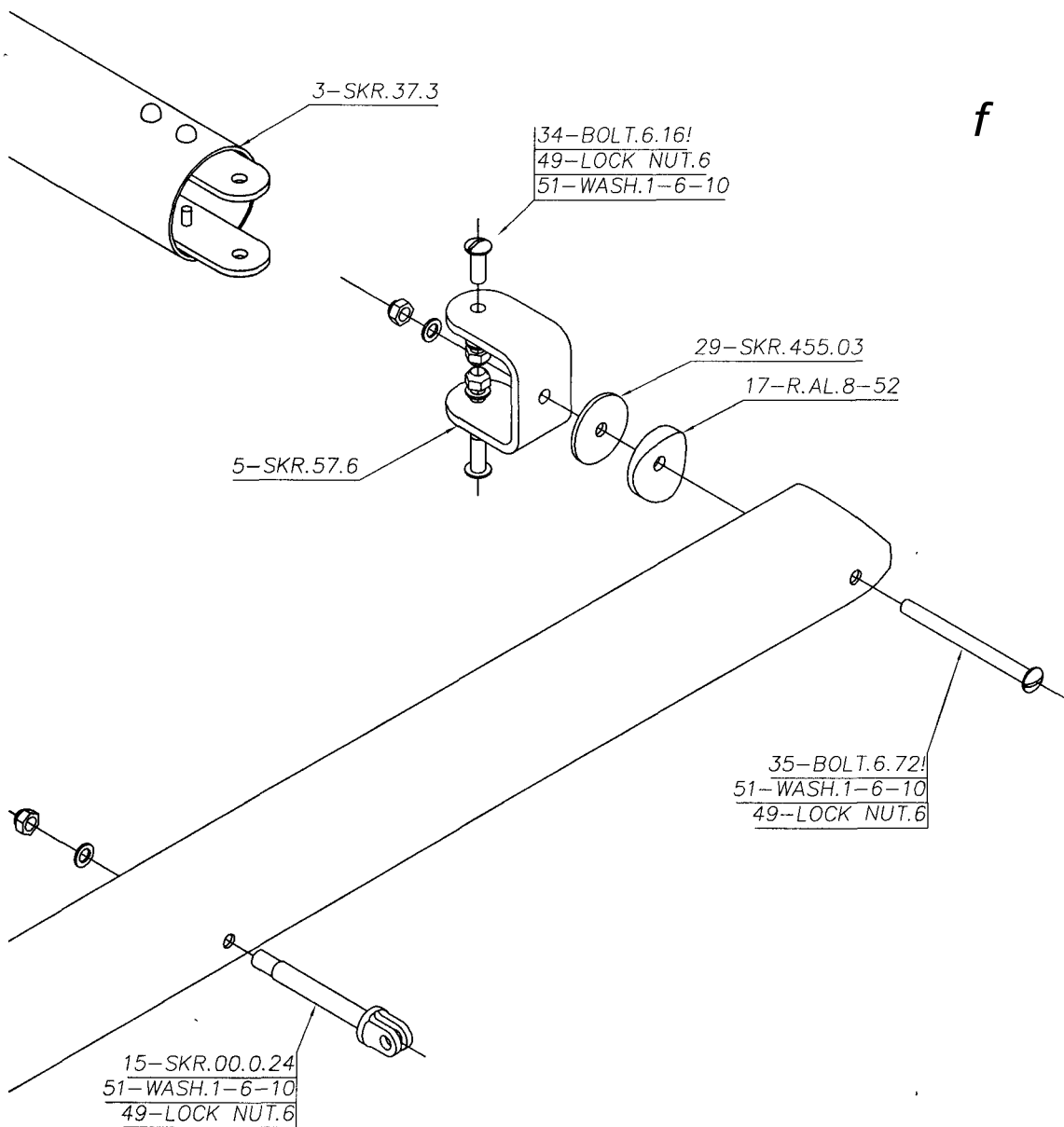
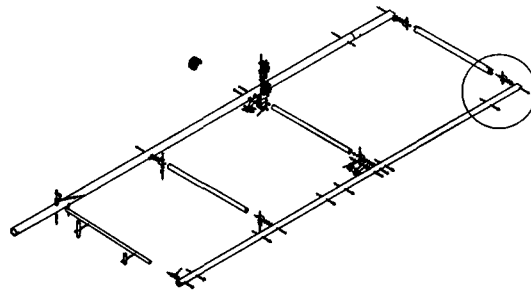

SKR. TK.28

1-SKR.115.2



2-SKR.115.3



SKR. TK.29

1-SKR.186

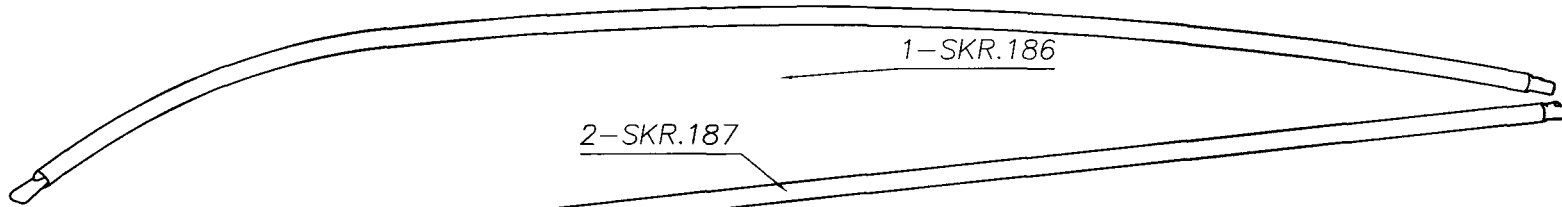

2-SKR.187

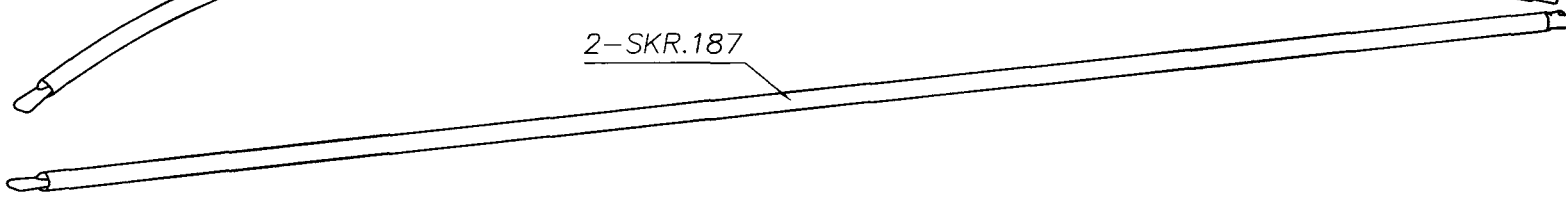

3-SKR.184

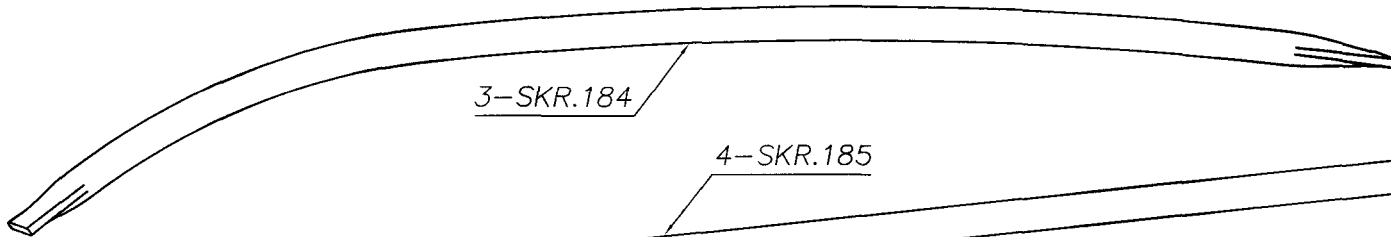

4-SKR.185

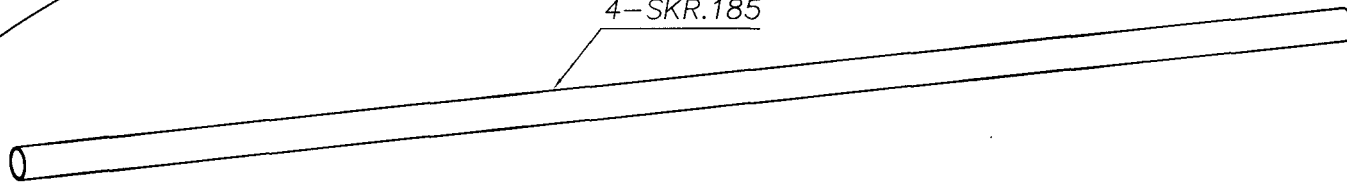

SKR. TK. 31

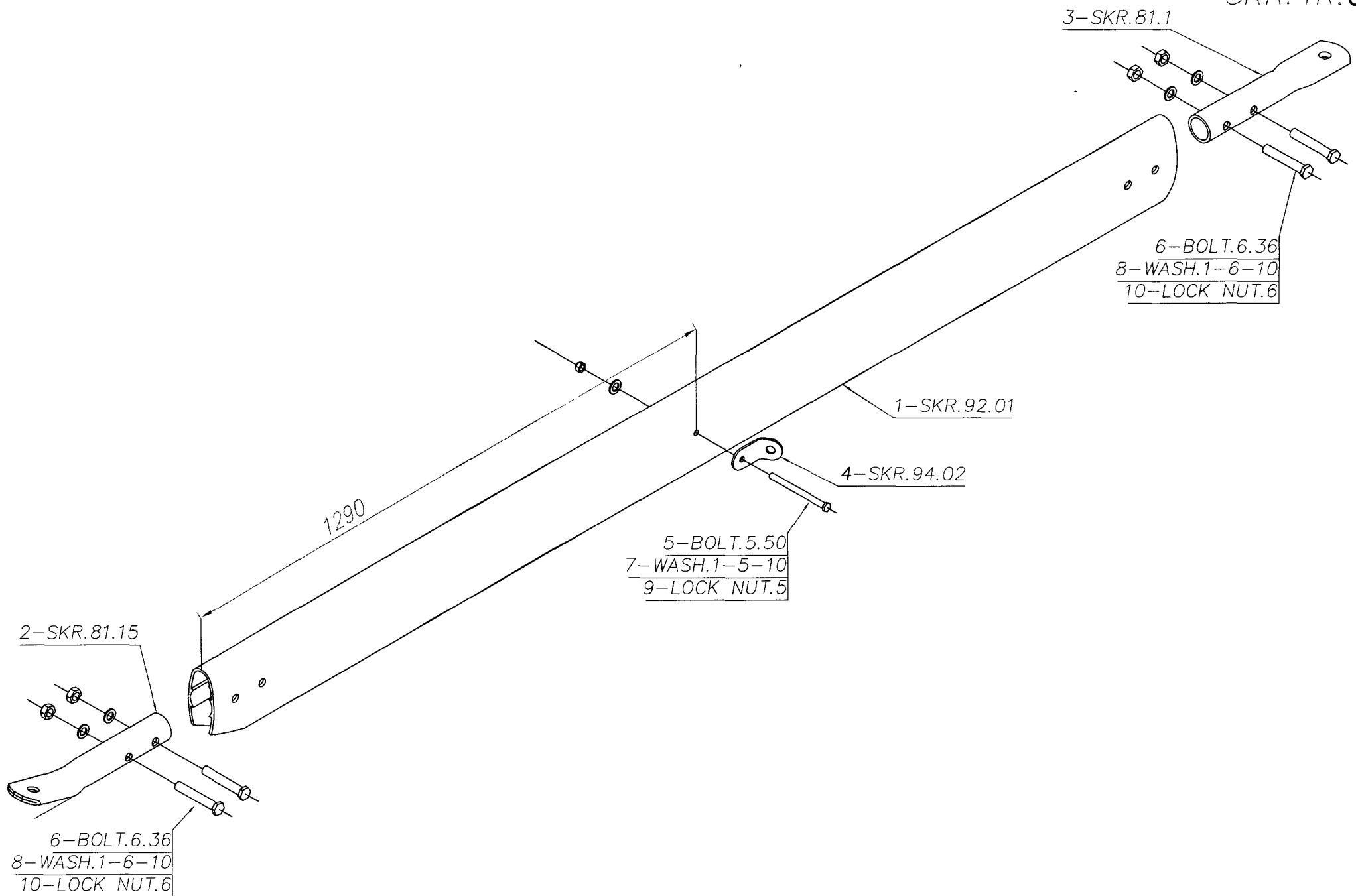

3-SKR.81.1

6-BOLT.6.36
8-WASH.1-6-10
10-LOCK NUT.6

1-SKR.92.01

4-SKR.94.02

5-BOLT.5.50
7-WASH.1-5-10
9-LOCK NUT.5

2-SKR.81.15

6-BOLT.6.36
8-WASH.1-6-10
10-LOCK NUT.6

1290

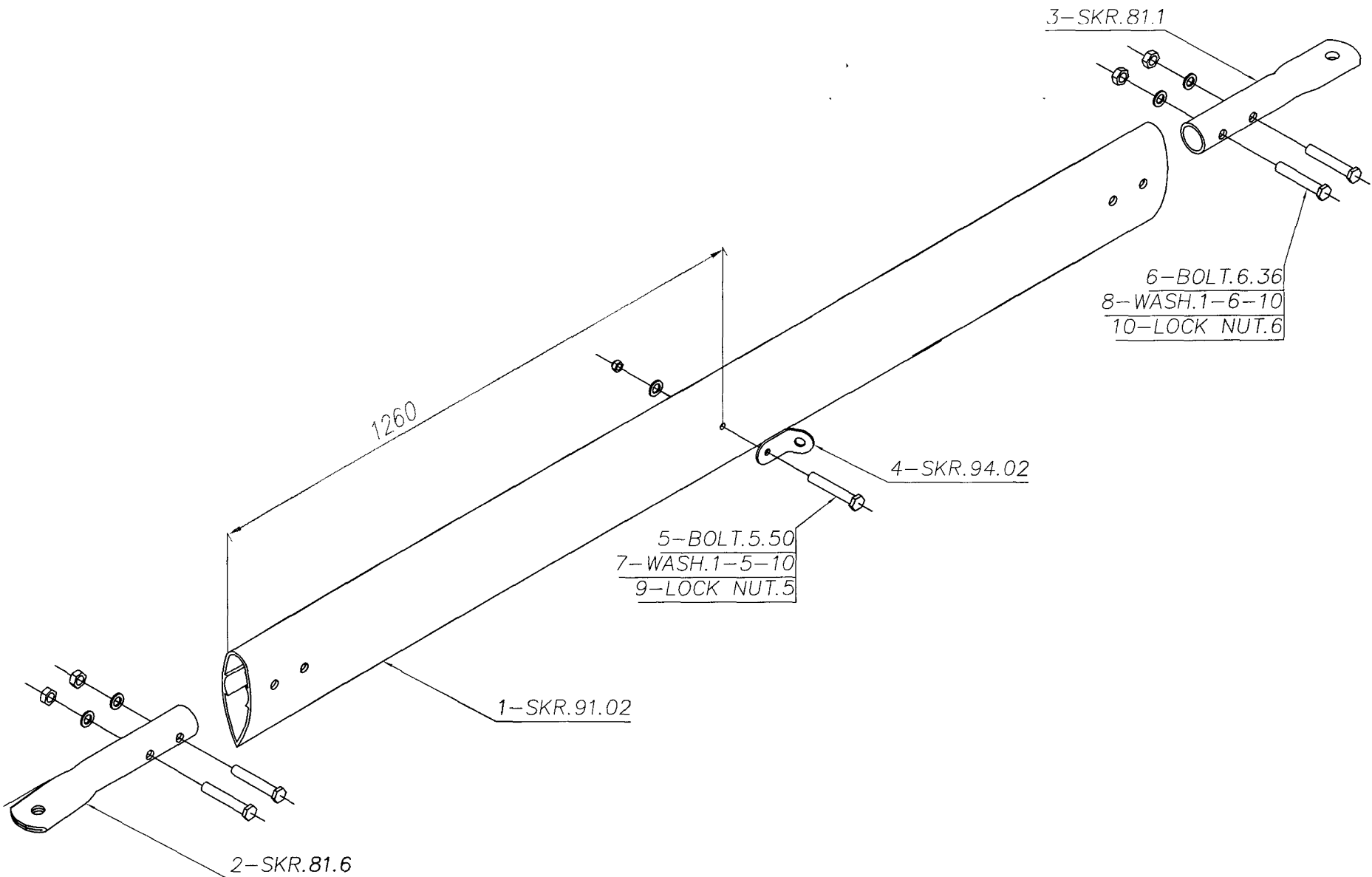

1260

3-SKR.81.1

6-BOLT.6.36
8-WASH.1-6-10
10-LOCK NUT.6

4-SKR.94.02

5-BOLT.5.50
7-WASH.1-5-10
9-LOCK NUT.5

1-SKR.91.02

2-SKR.81.6

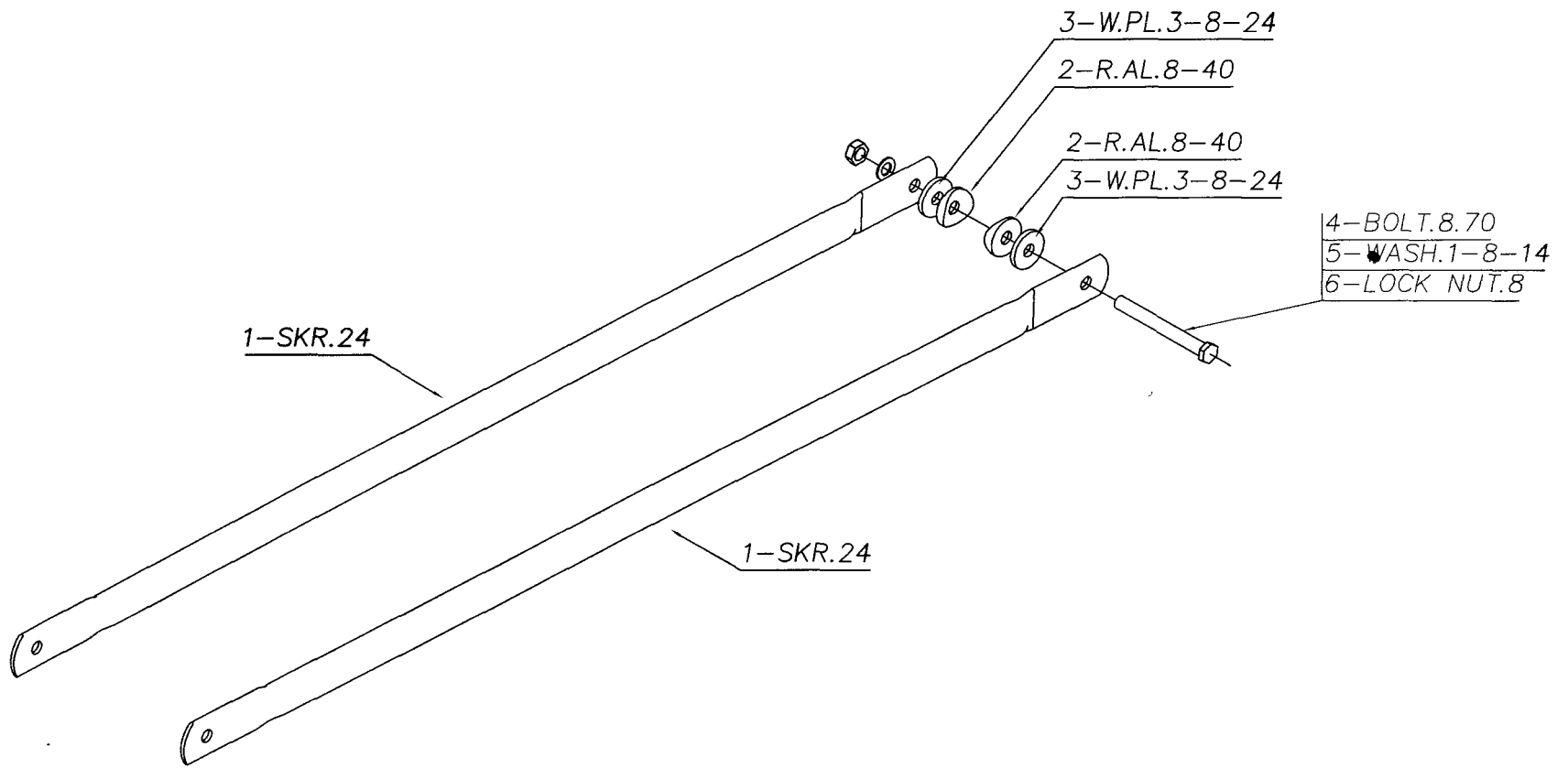

1-SKR.24

1-SKR.24

3-W.PL.3-8-24

2-R.AL.8-40

2-R.AL.8-40

3-W.PL.3-8-24

4-BOLT.8.70
5-WASH.1-8-14
6-LOCK NUT.8

7-BOLT.8.76
8-WASH.1-8-14
9-LOCK NUT.8

7-BOLT.8.76
8-WASH.1-8-14
9-LOCK NUT.8

12-SKR.500

5-W.PL.3-8-24

6-W.PL.7-8-24

11-R.PL.8-40

11-R.PL.8-40

6-W.PL.7-8-24

5-W.PL.3-8-24

3-R.AL.8-36

6-W.PL.7-8-24

3-R.AL.8-36

3-R.AL.8-36

1-SKR.98

3-R.AL.8-36

4-W.FL.1-8-24

5-W.PL.3-8-24

3-R.AL.8-36

3-R.AL.8-36

4-W.FL.1-8-24

6-W.PL.7-8-24

2-SKR.298

10-SKR.310

2-SKR.29

7-BOLT.8.76
8-WASH.1-8-14
9-LOCK NUT.8

7-BOLT.8.76
8-WASH.1-8-14
9-LOCK NUT.8

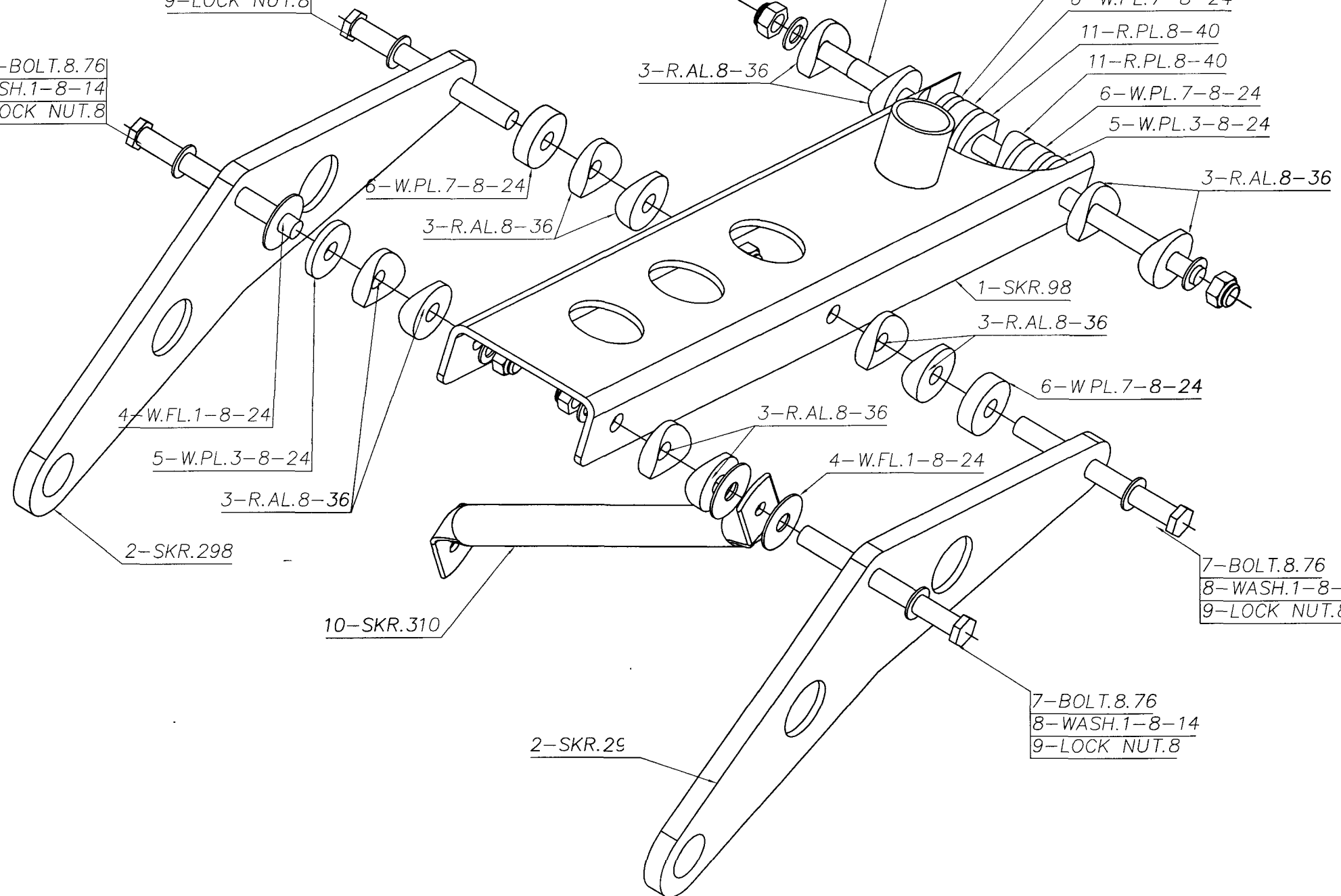

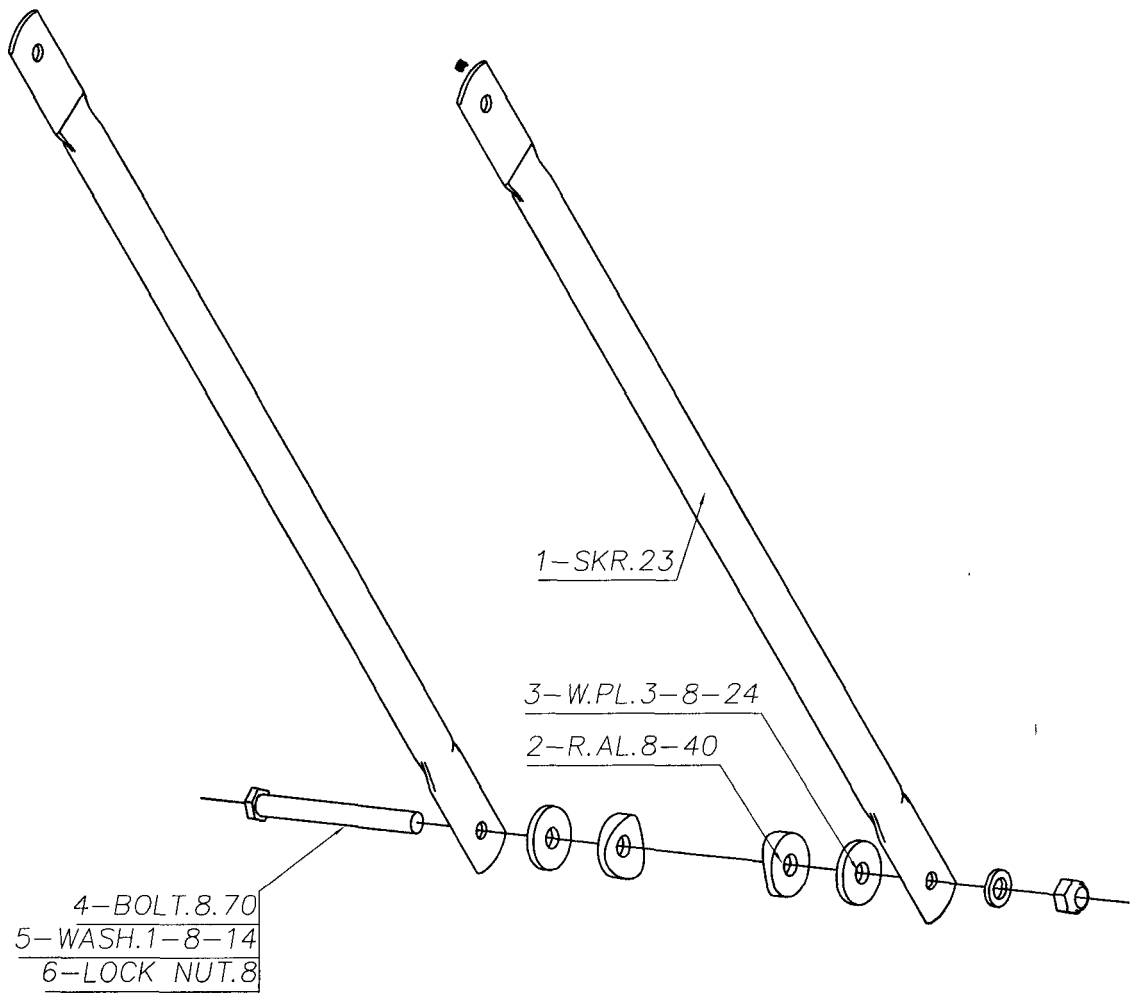

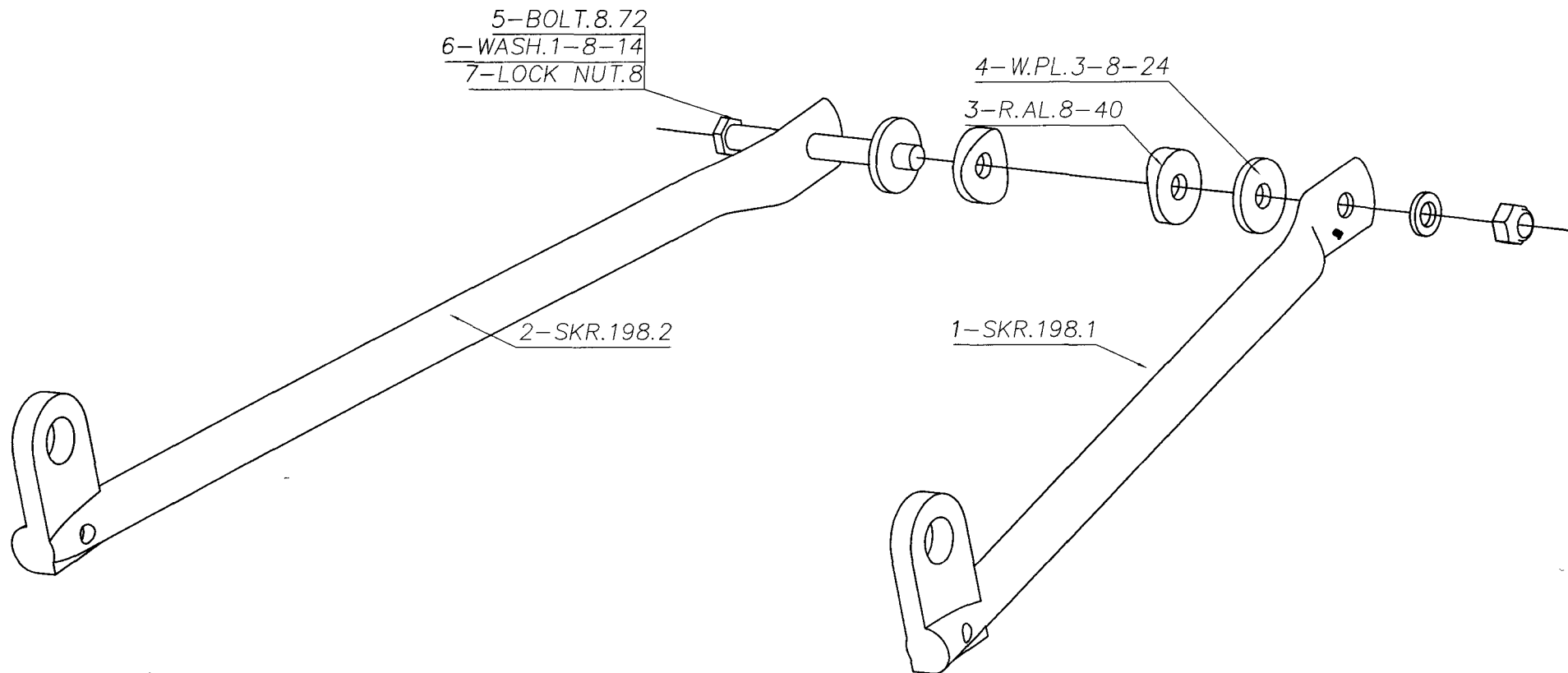

I 1:2

SKR.TK.38/1

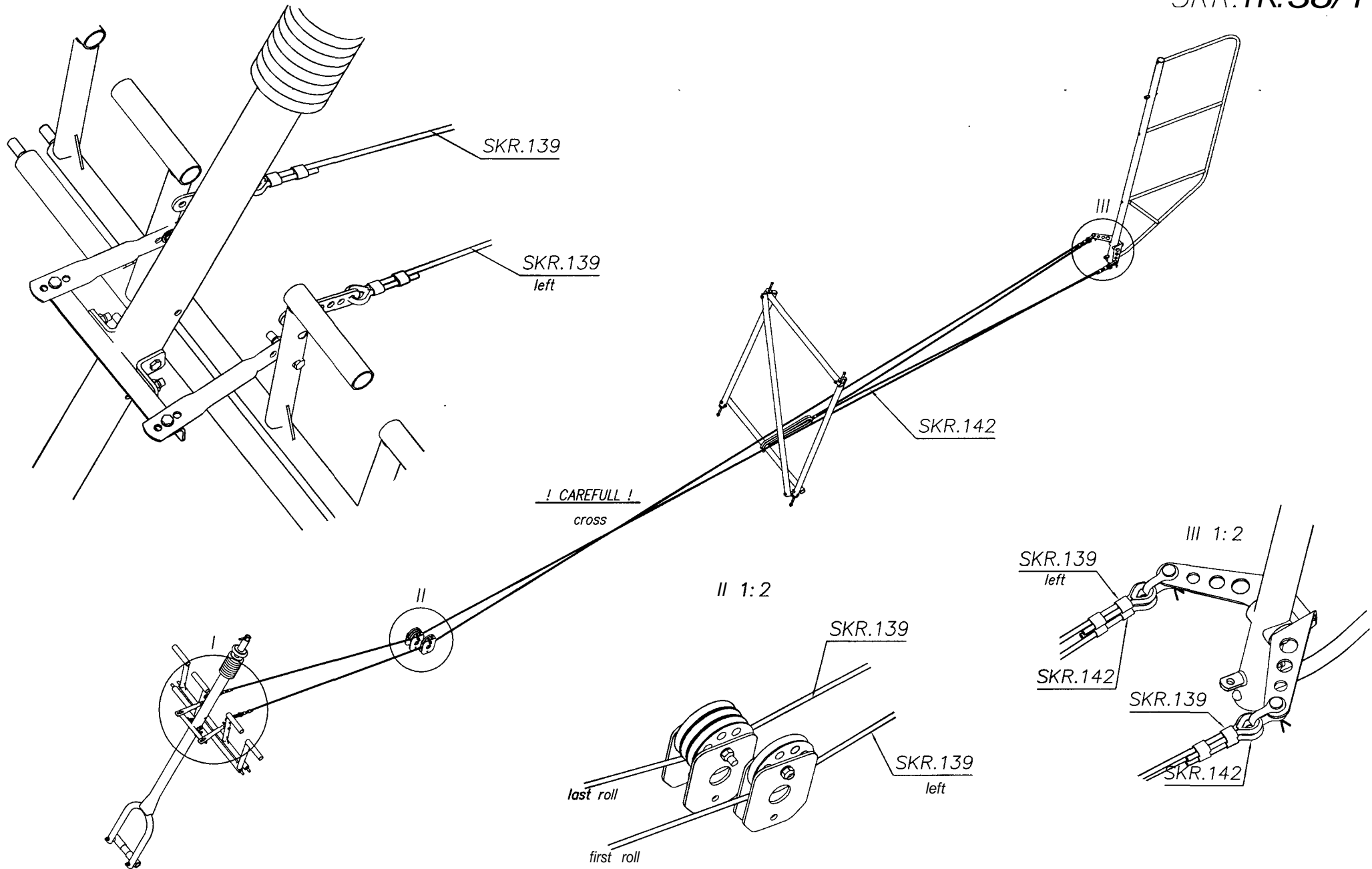

SKR. TK. 38/2

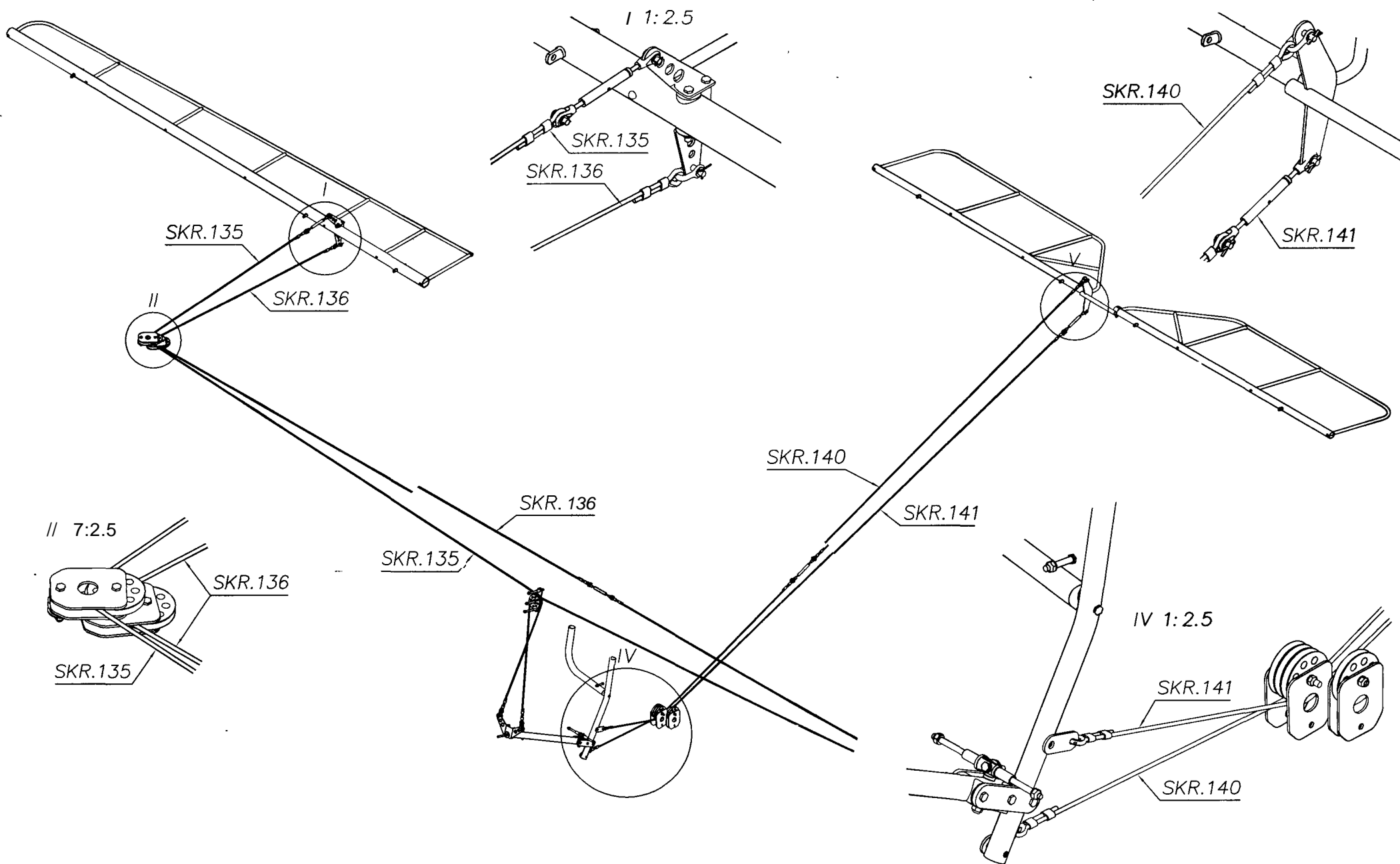

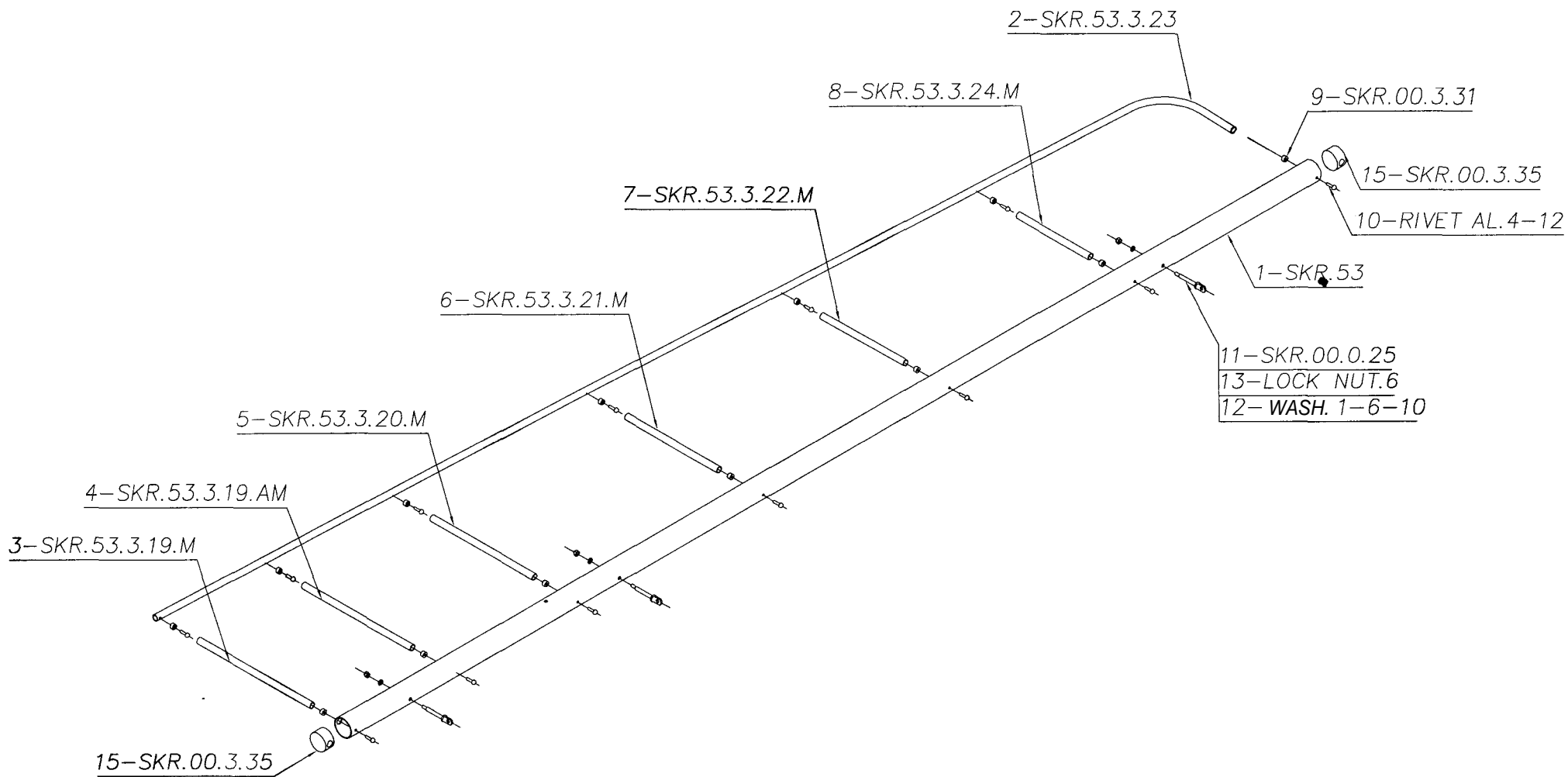

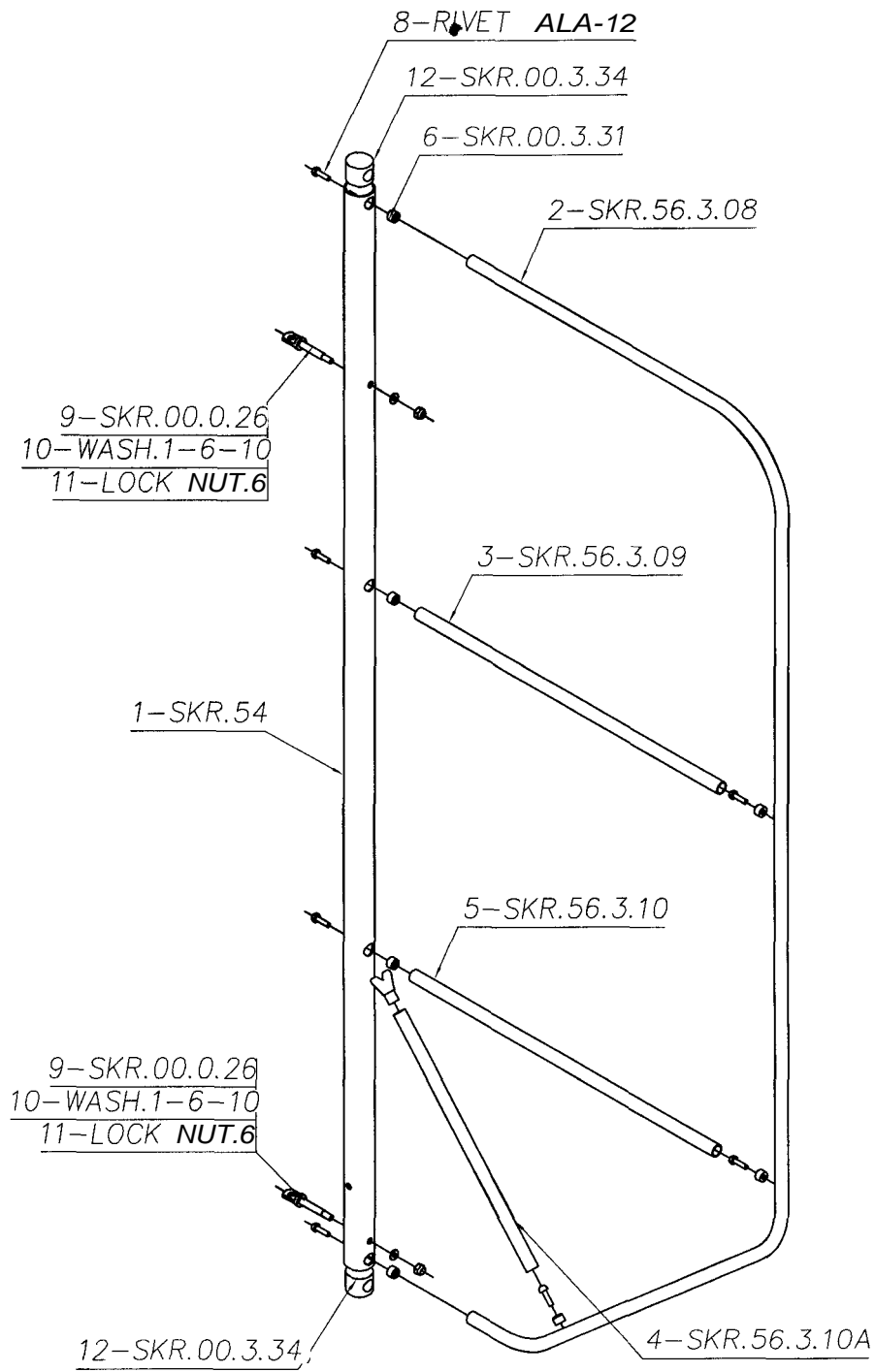

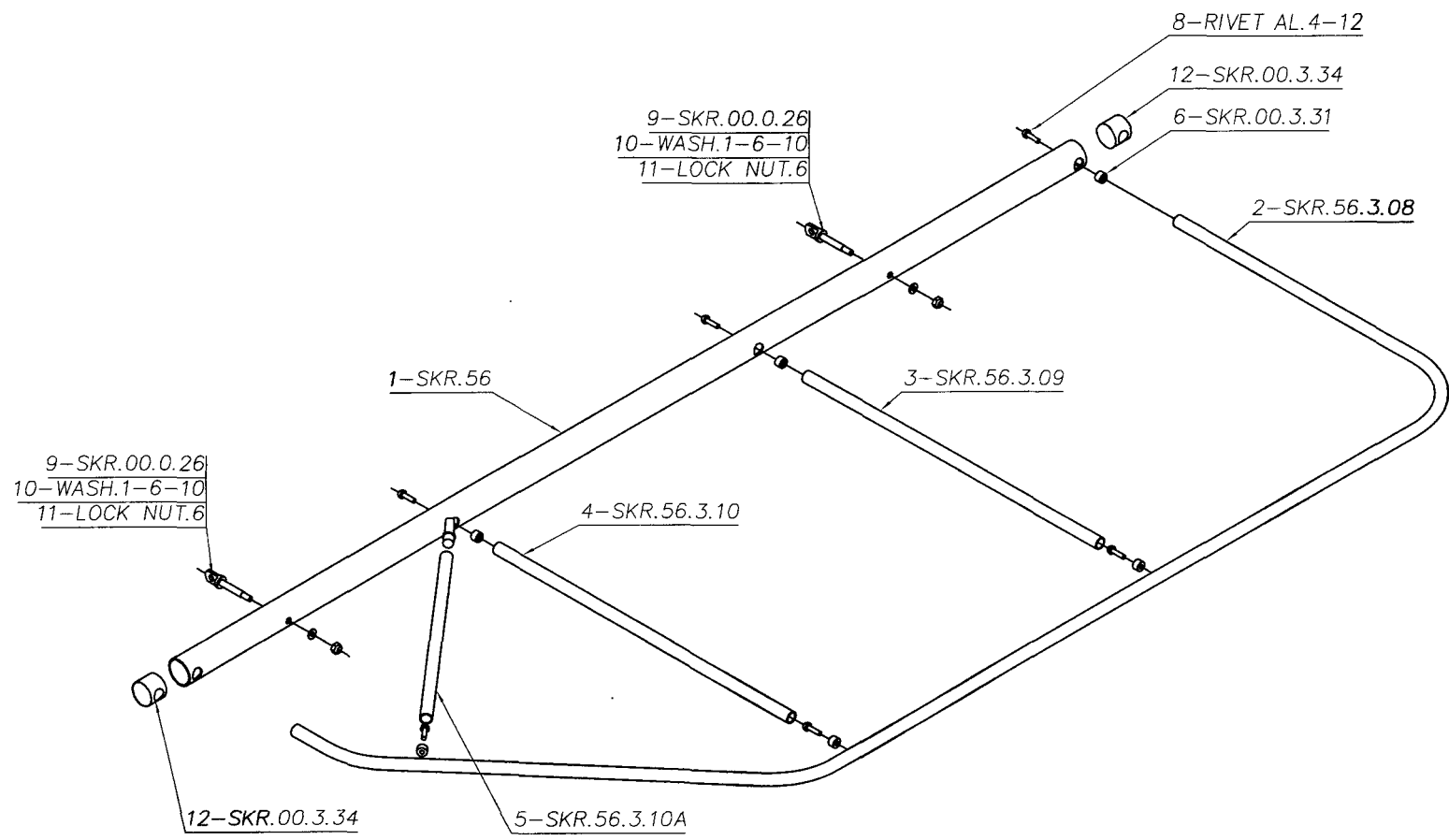

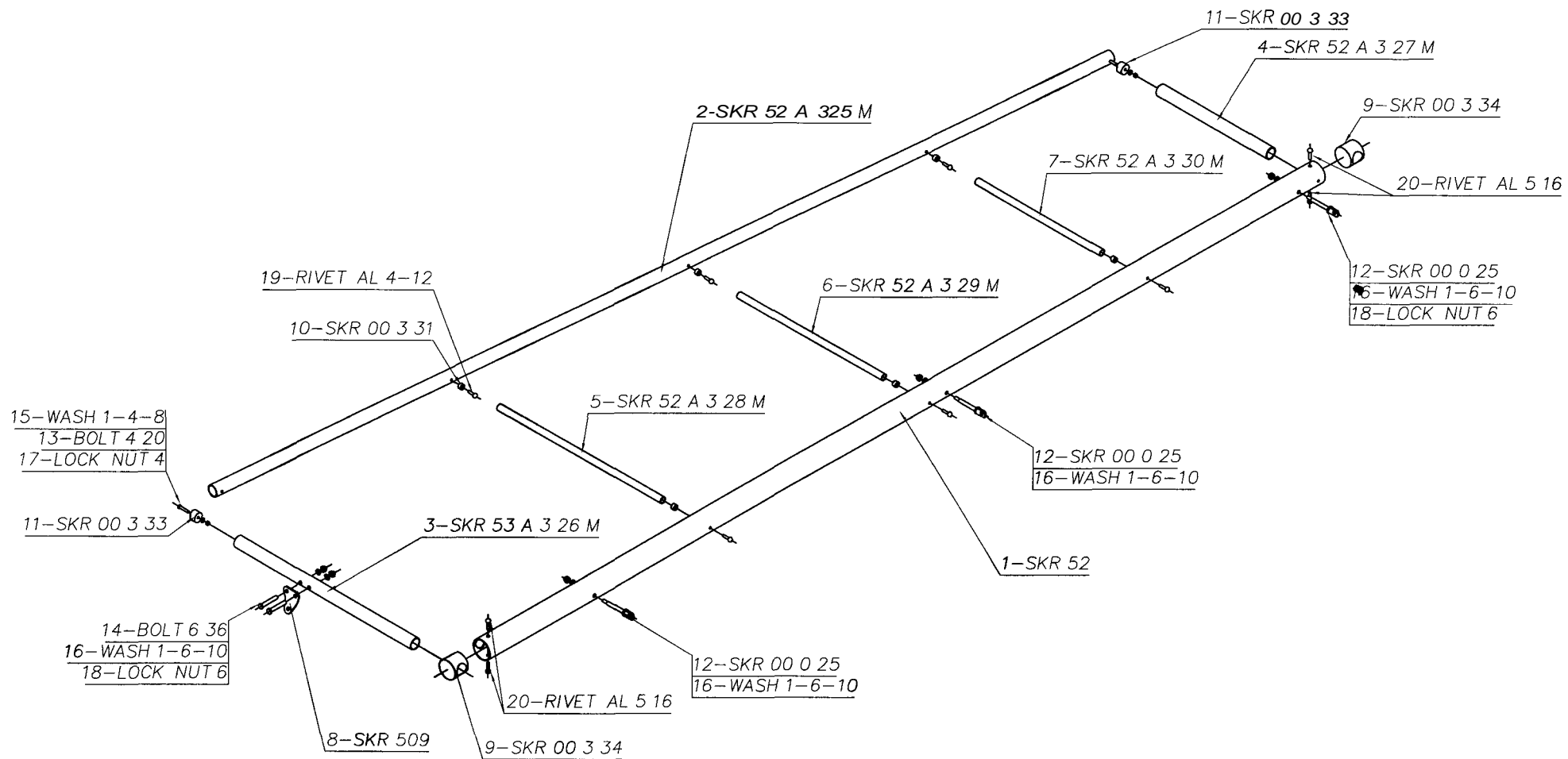

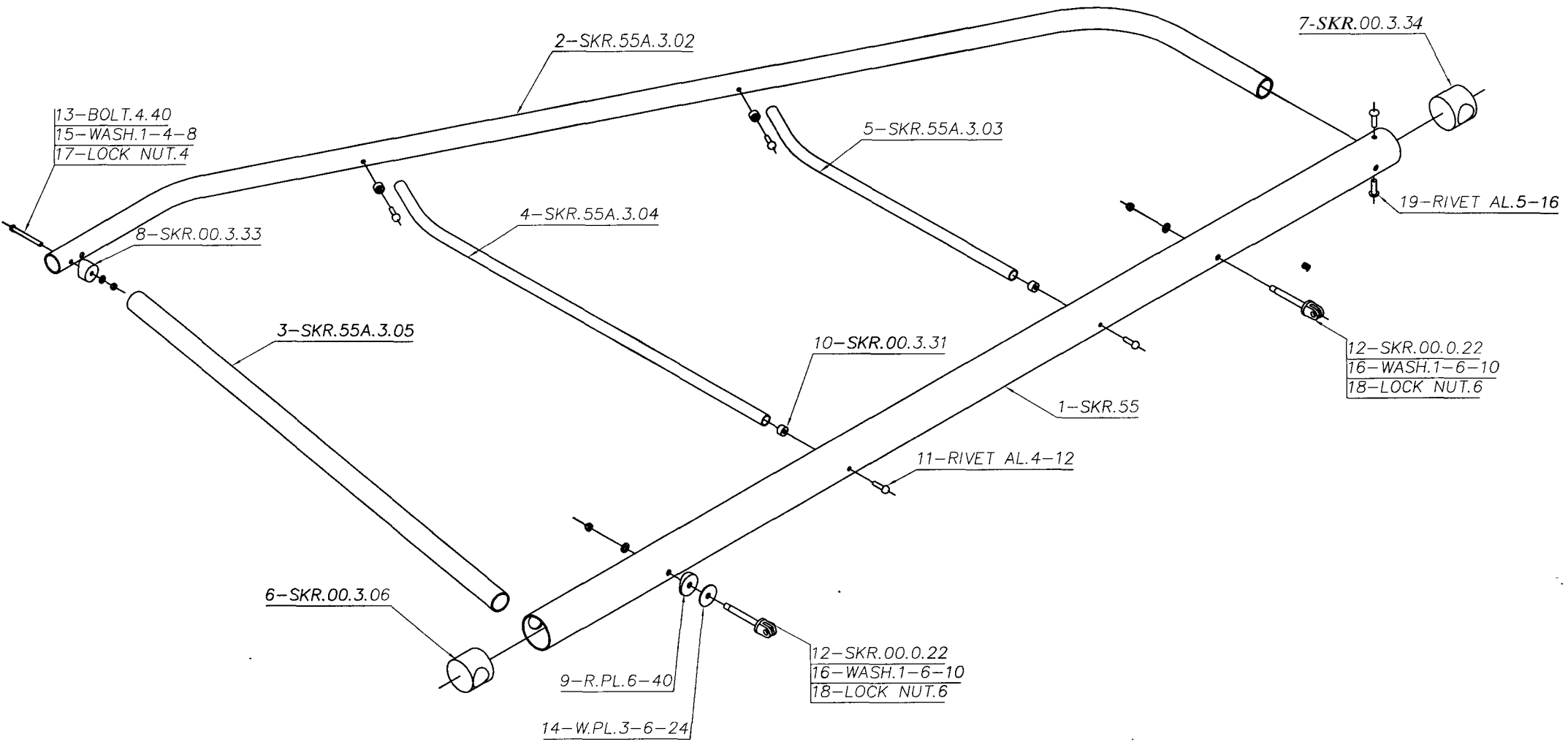

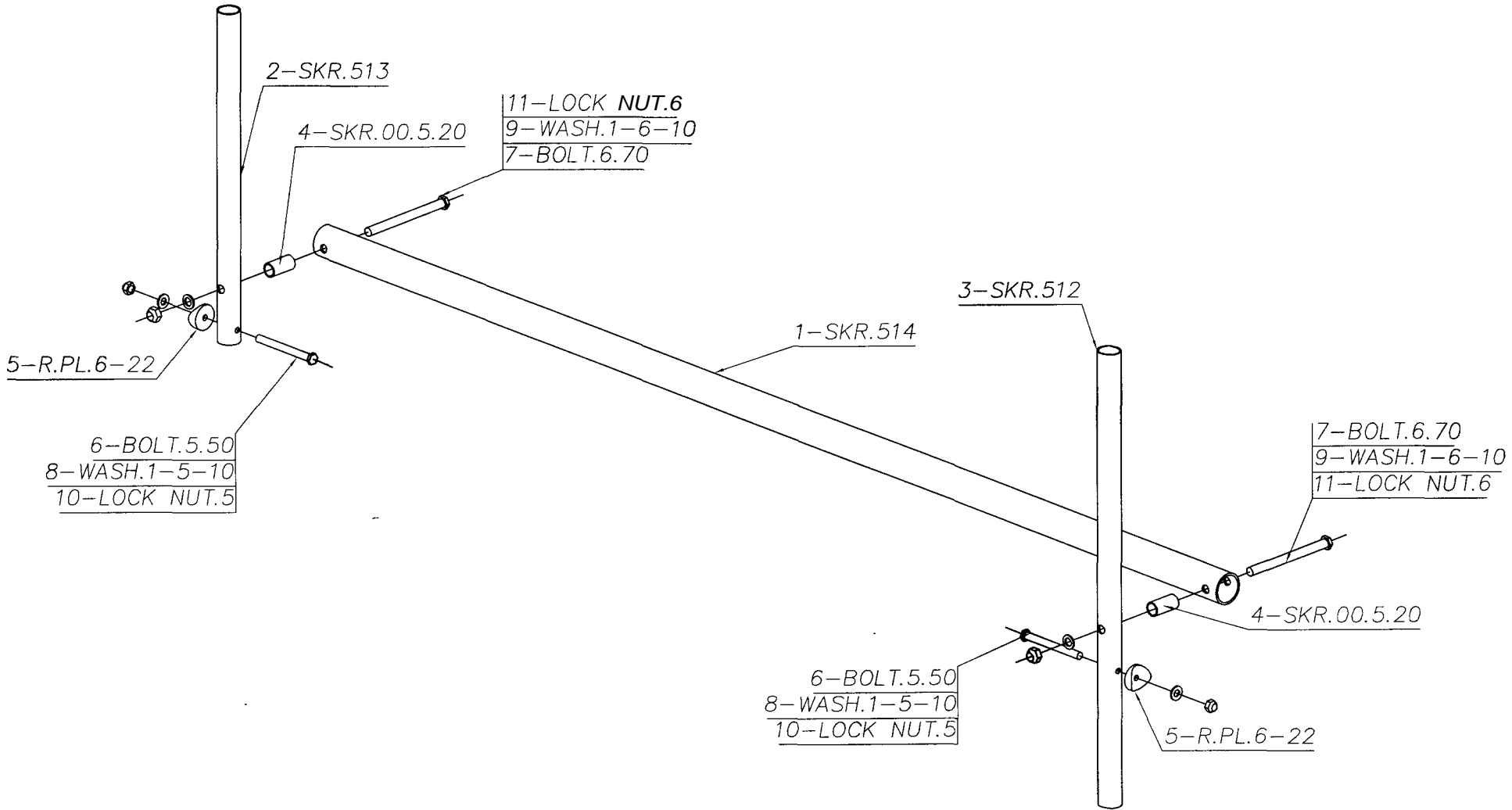

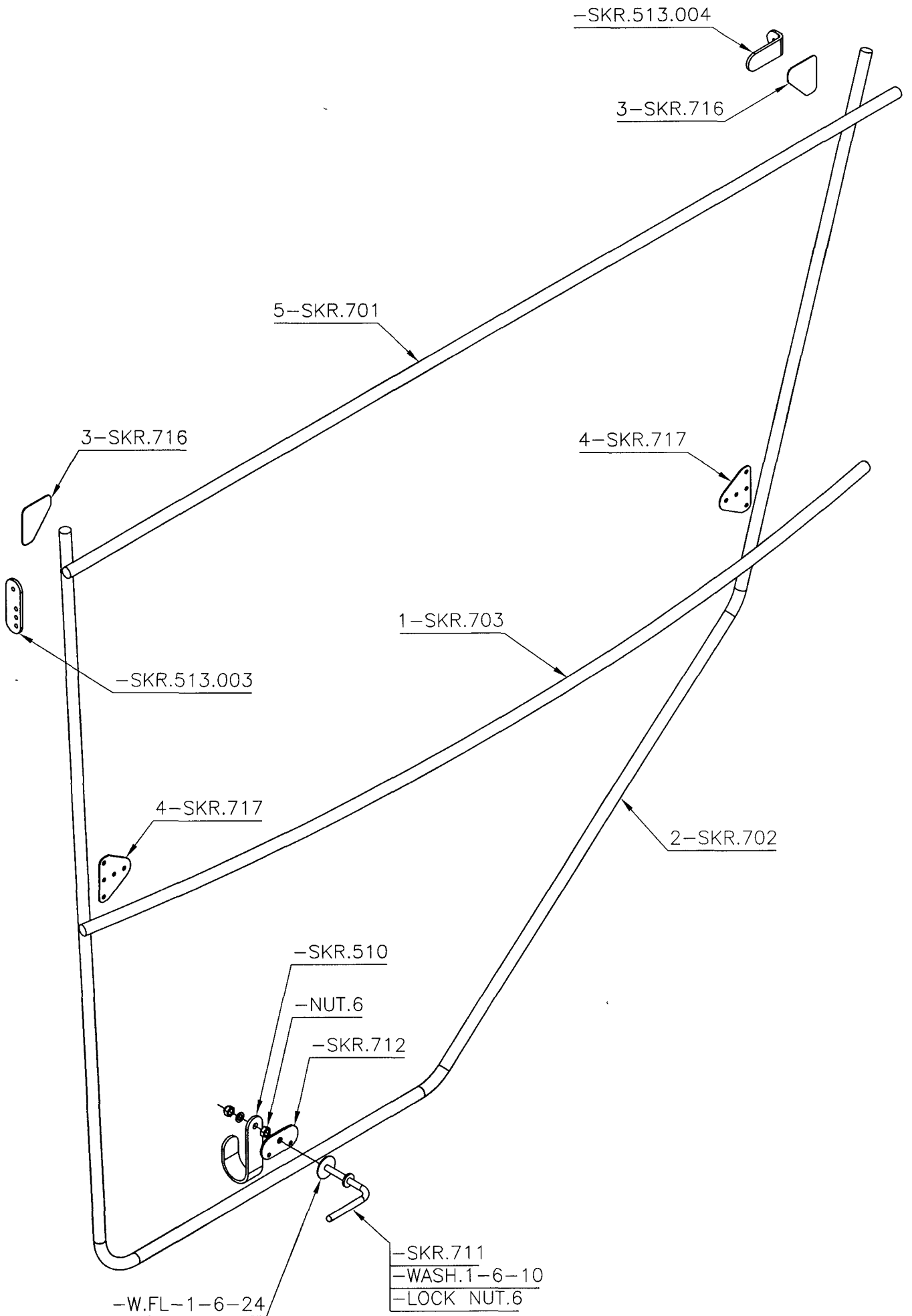

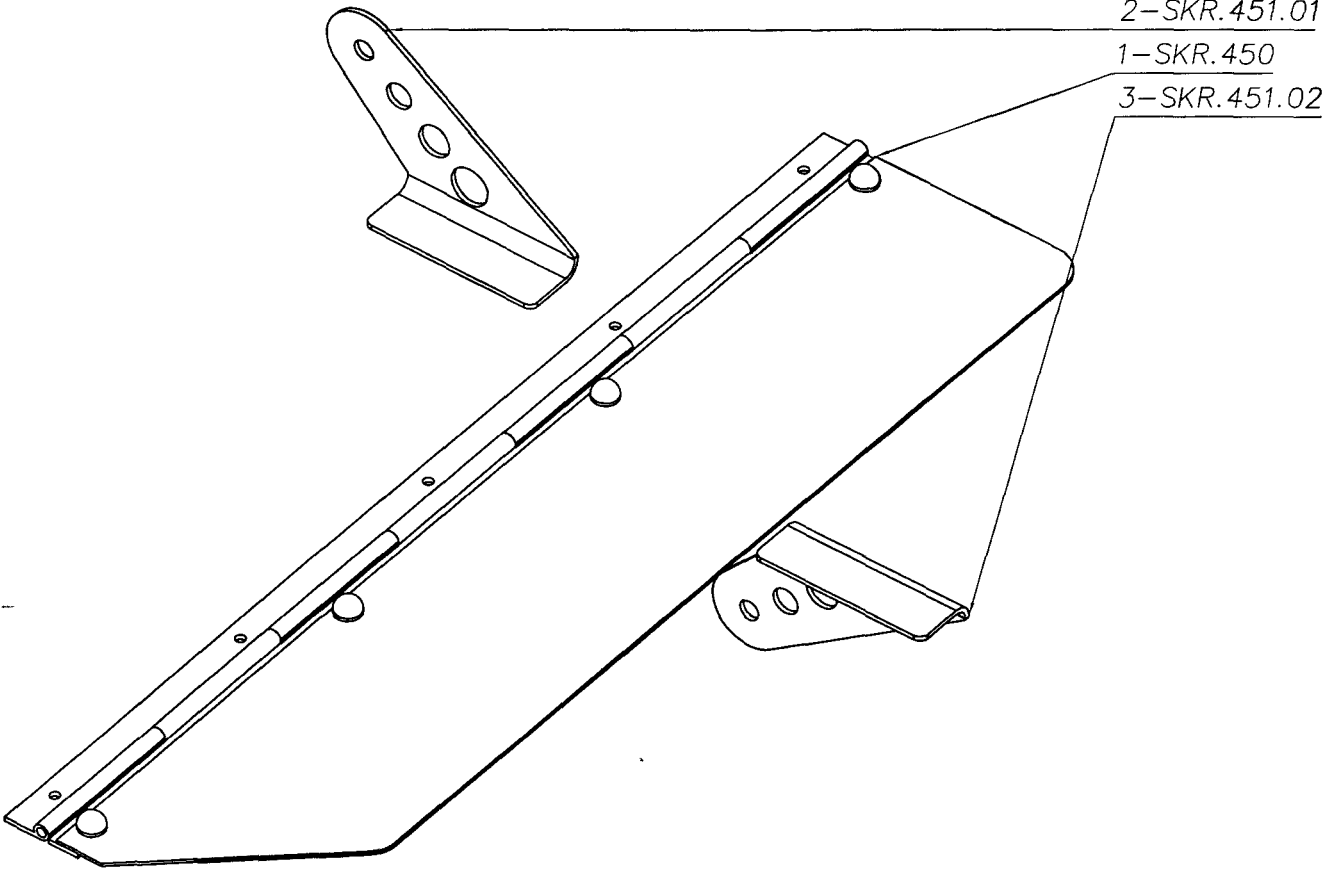

SKR. TK. 60

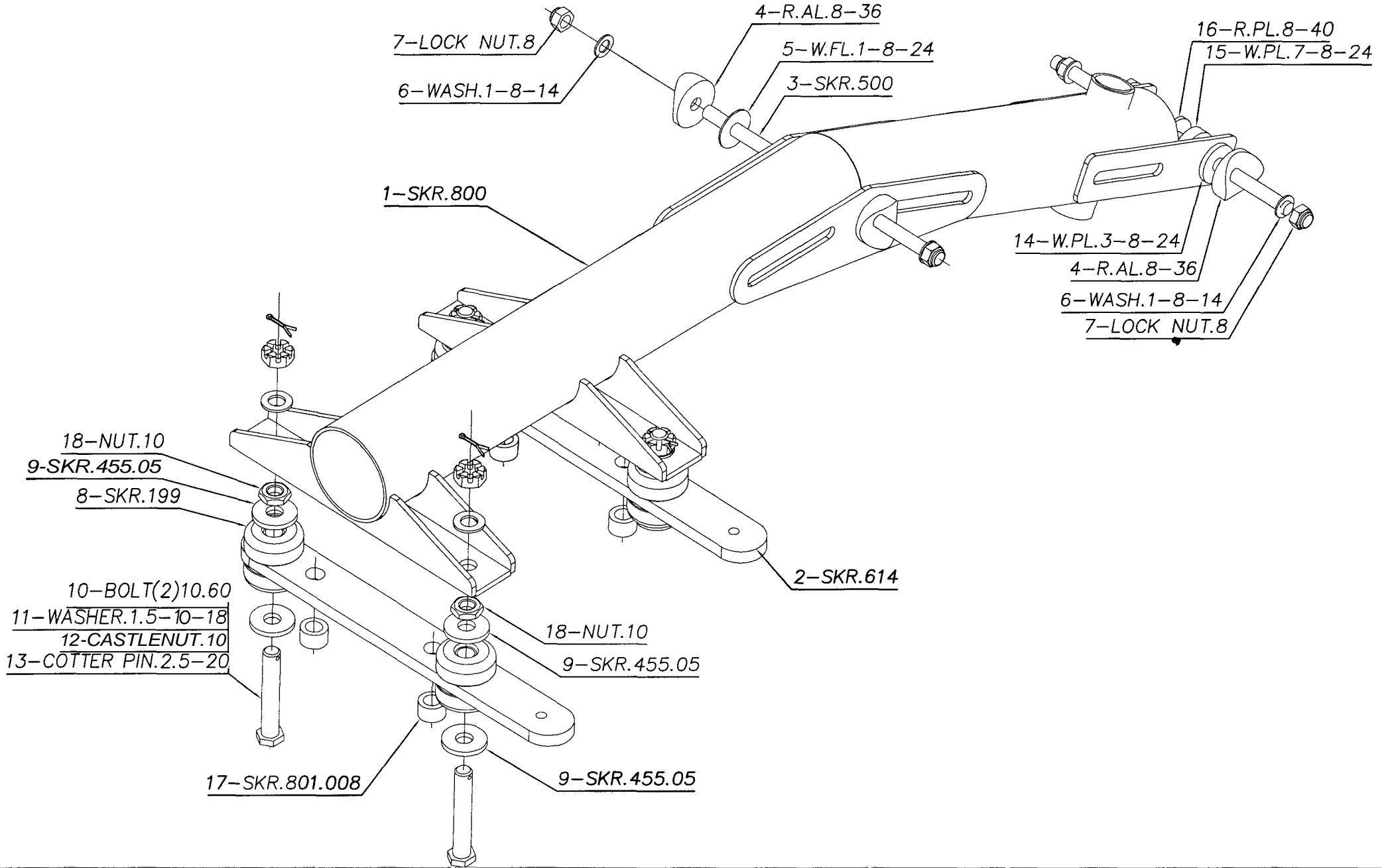

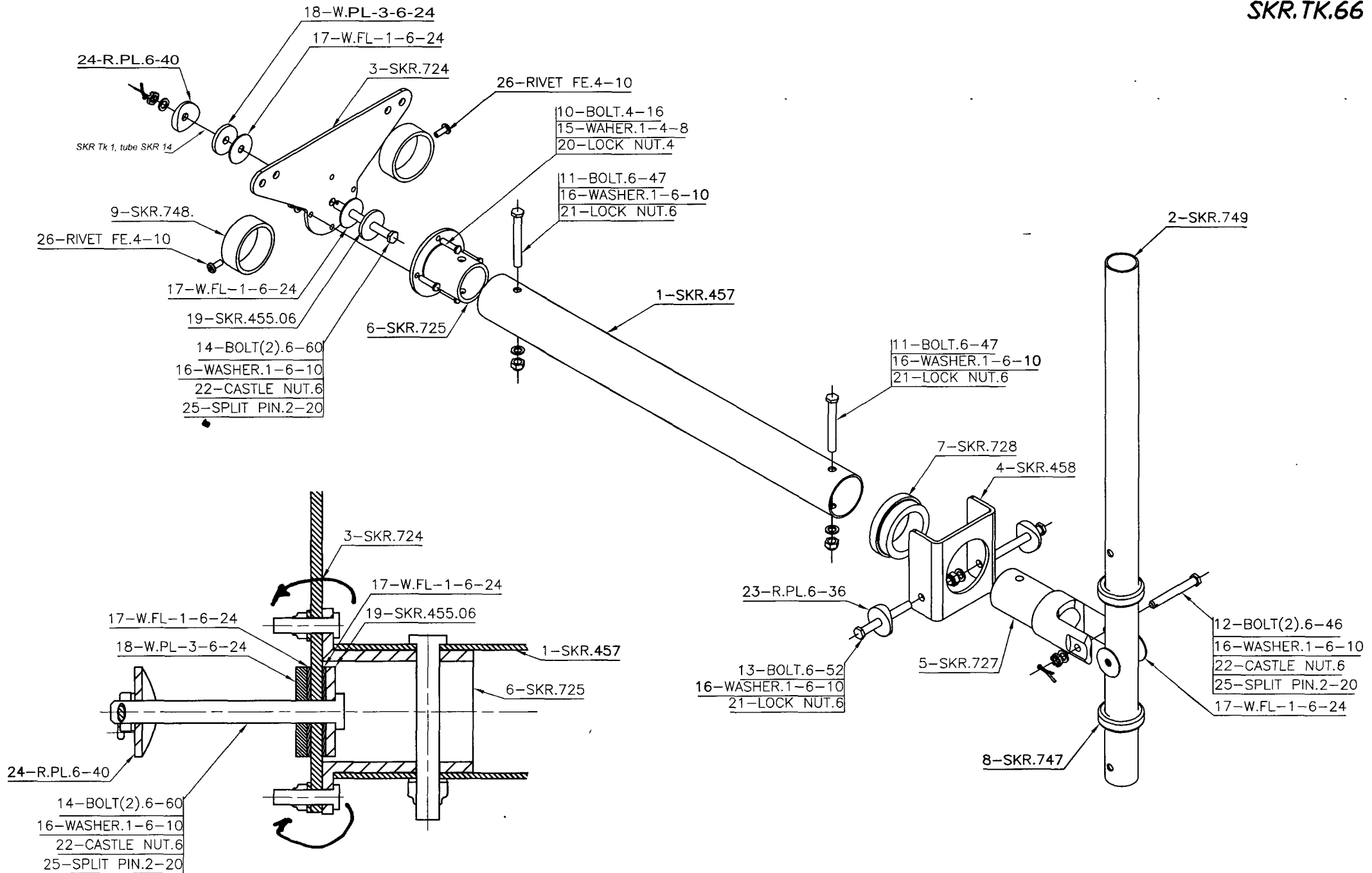

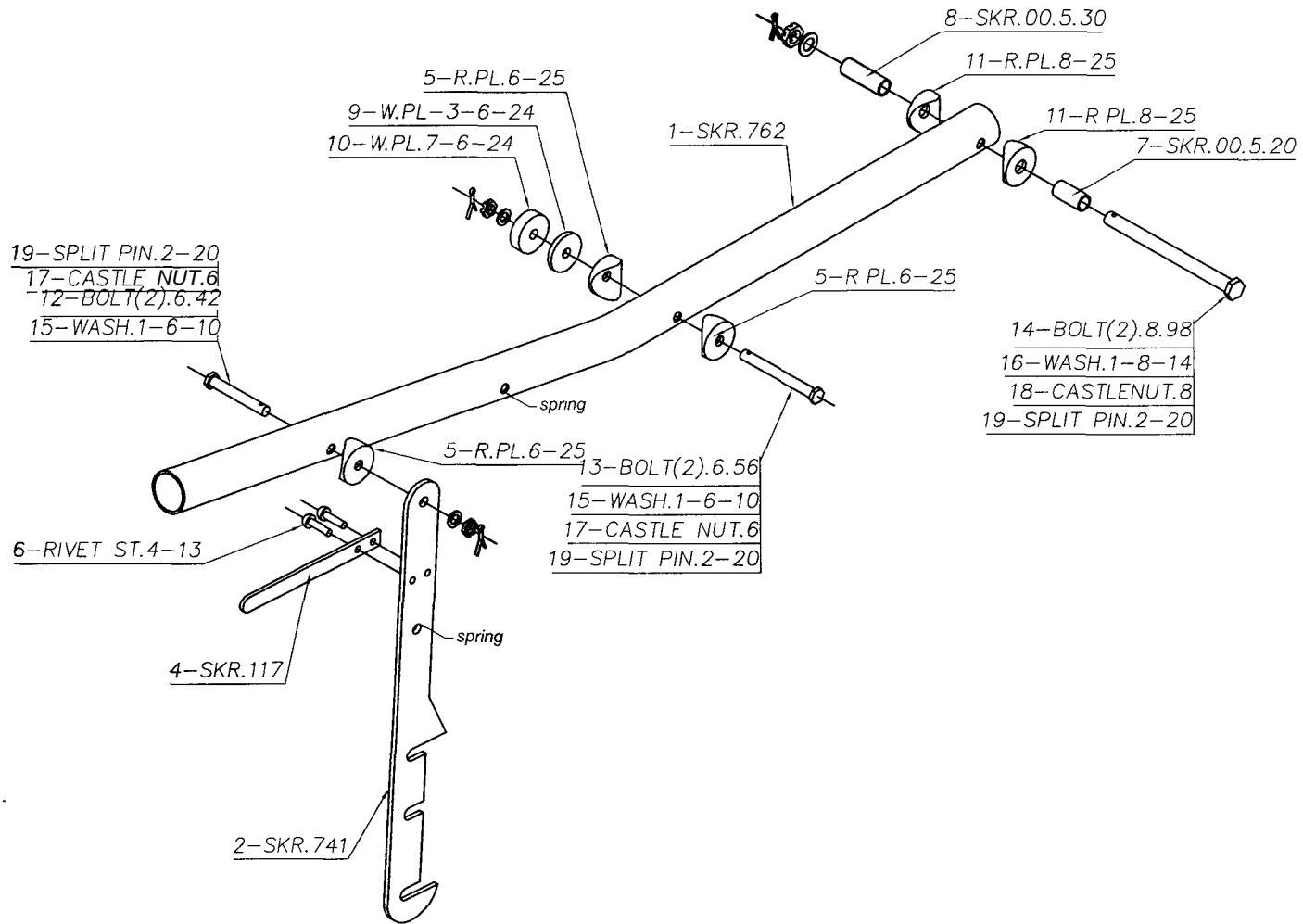

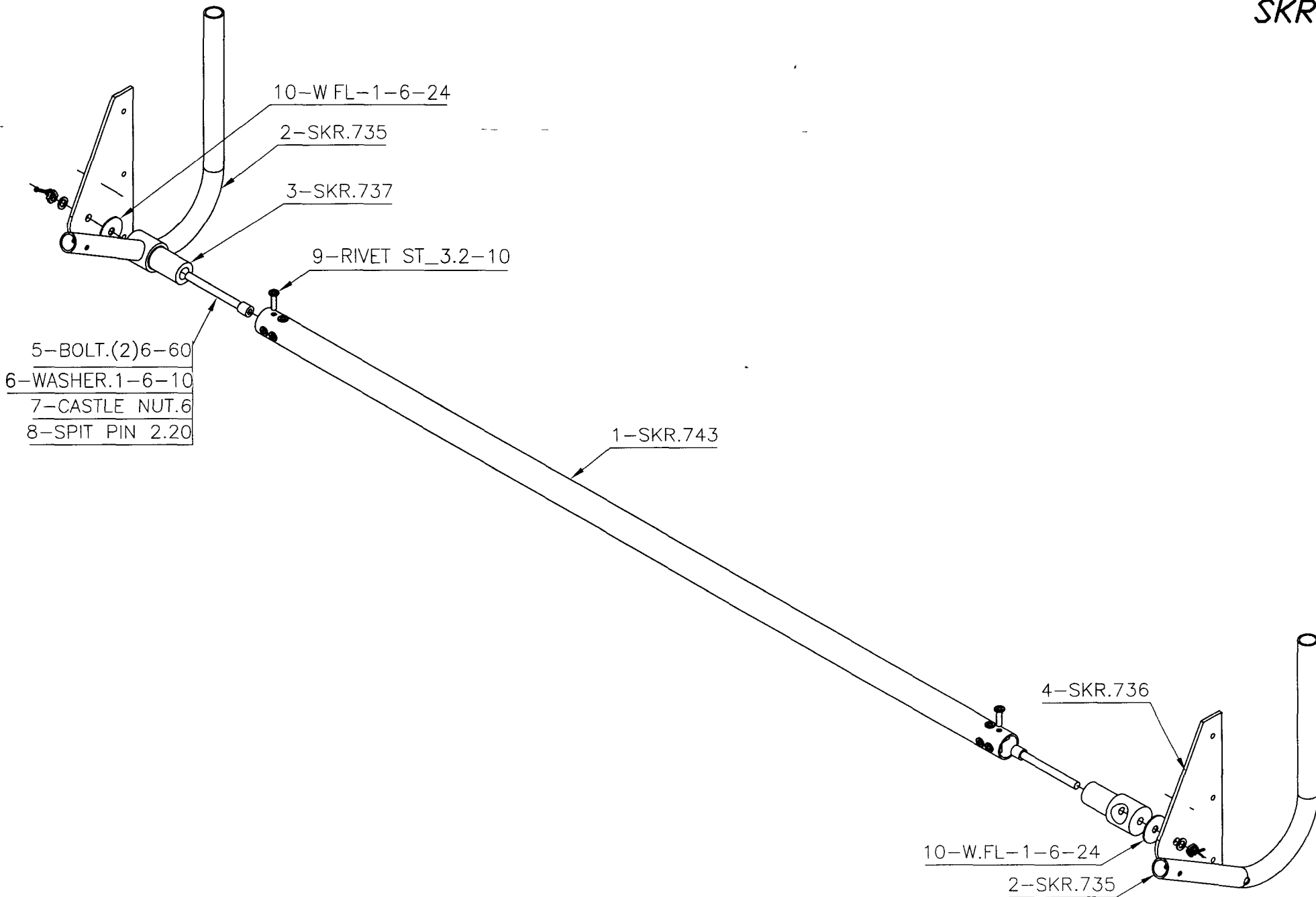

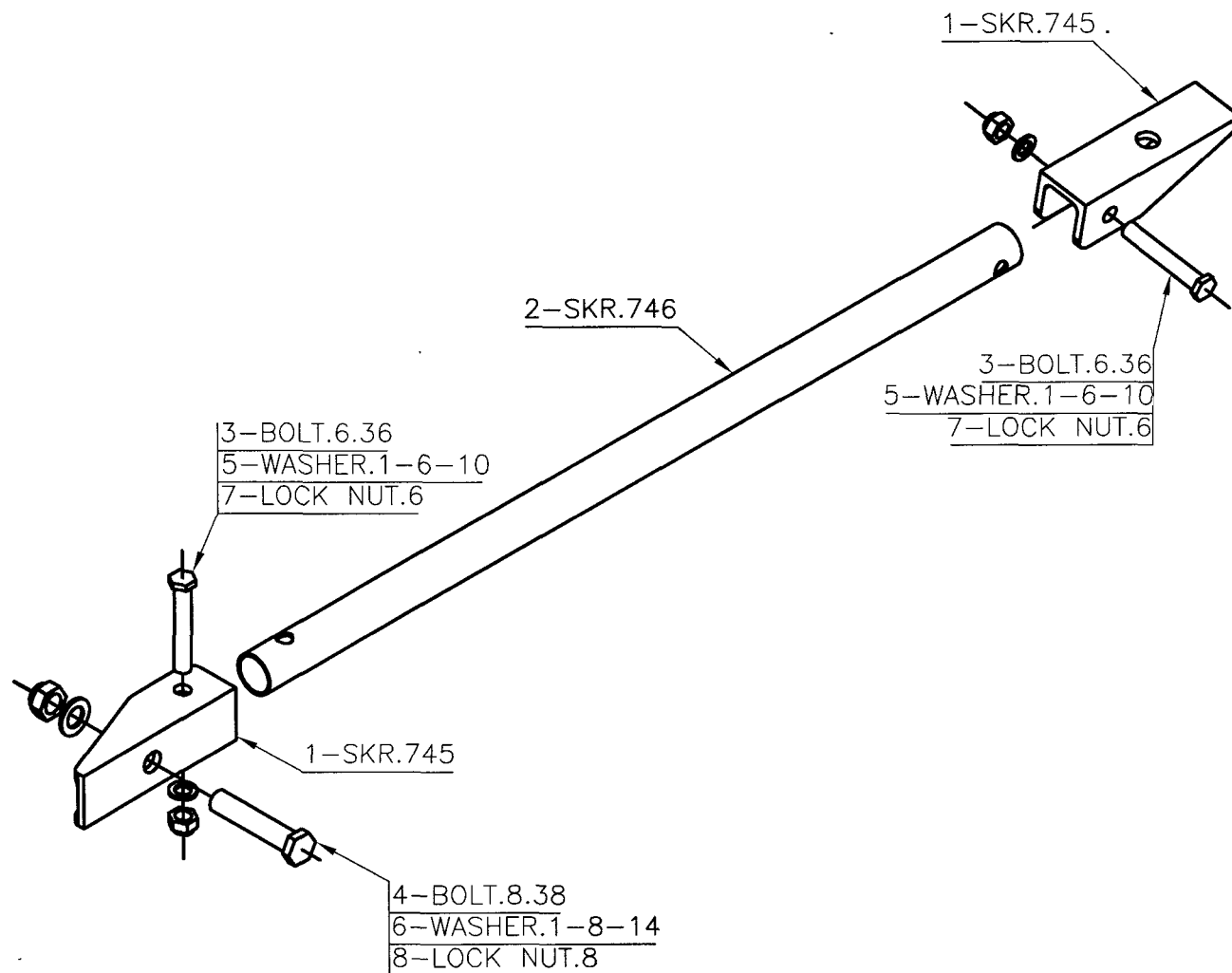

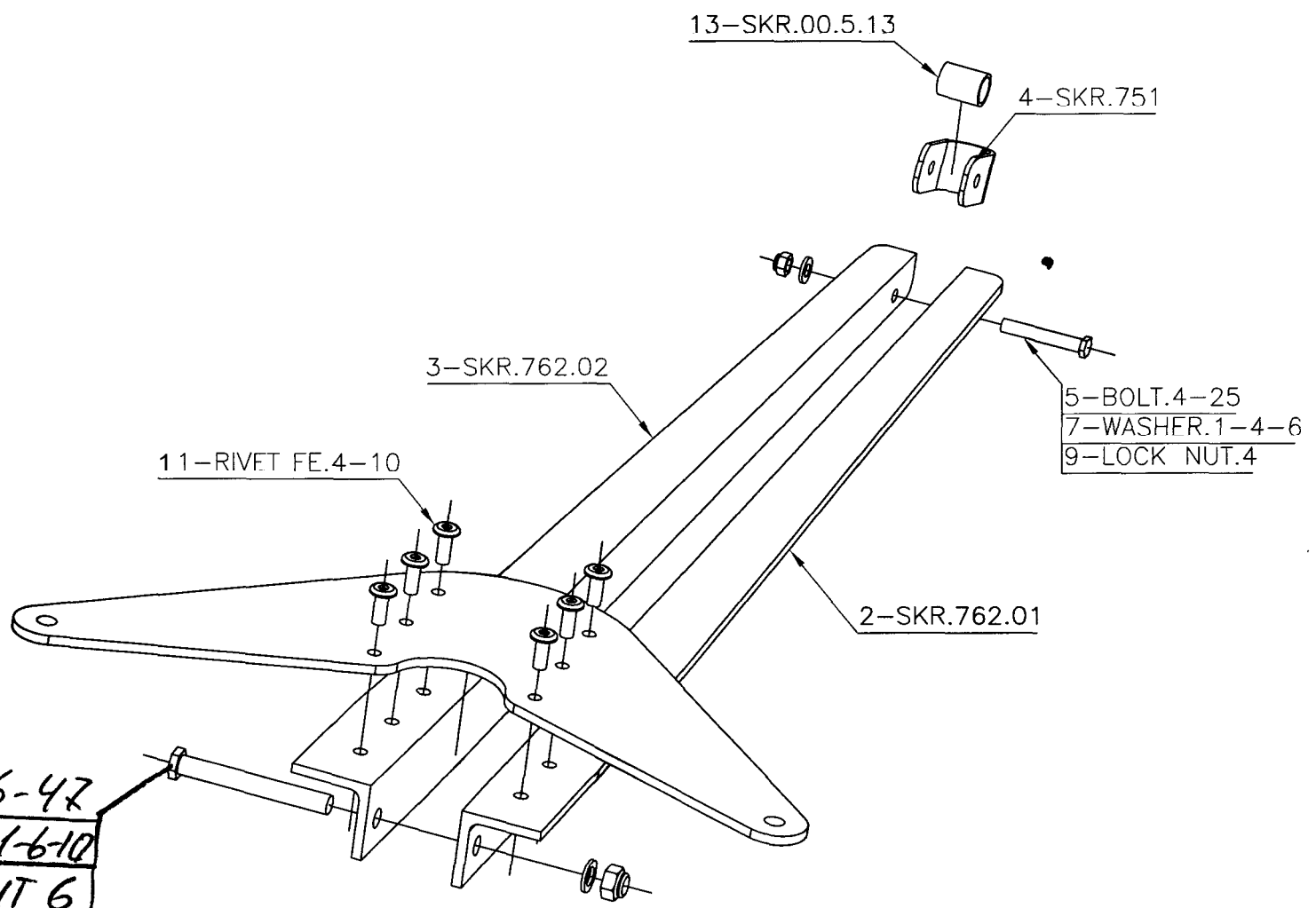
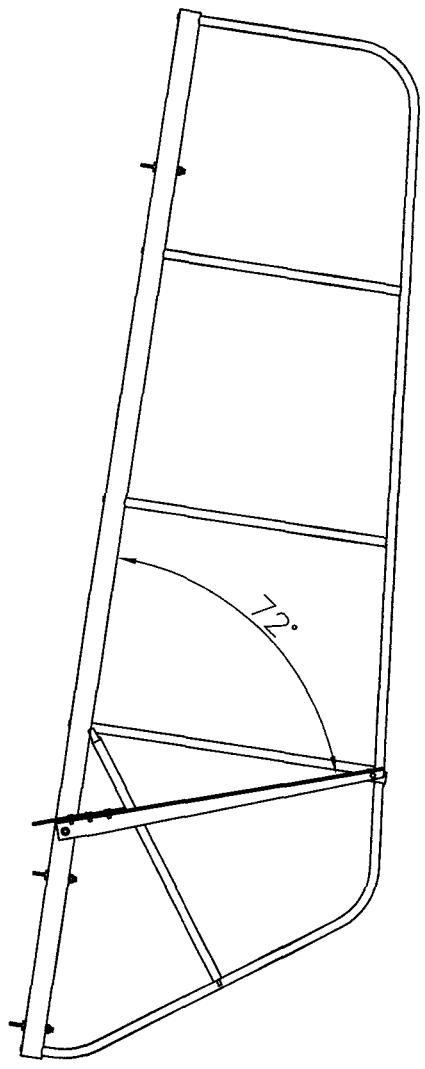

13-SKR.00.5.13

4-SKR.751

3-SKR.762.02

11-RIVET FE.4-10

5-BOLT.4-25
7-WASHER.1-4-6
9-LOCK NUT.4

2-SKR.762.01

14-BOLT 6-47
15-WASHER 6-10
16-LOC NUT 6

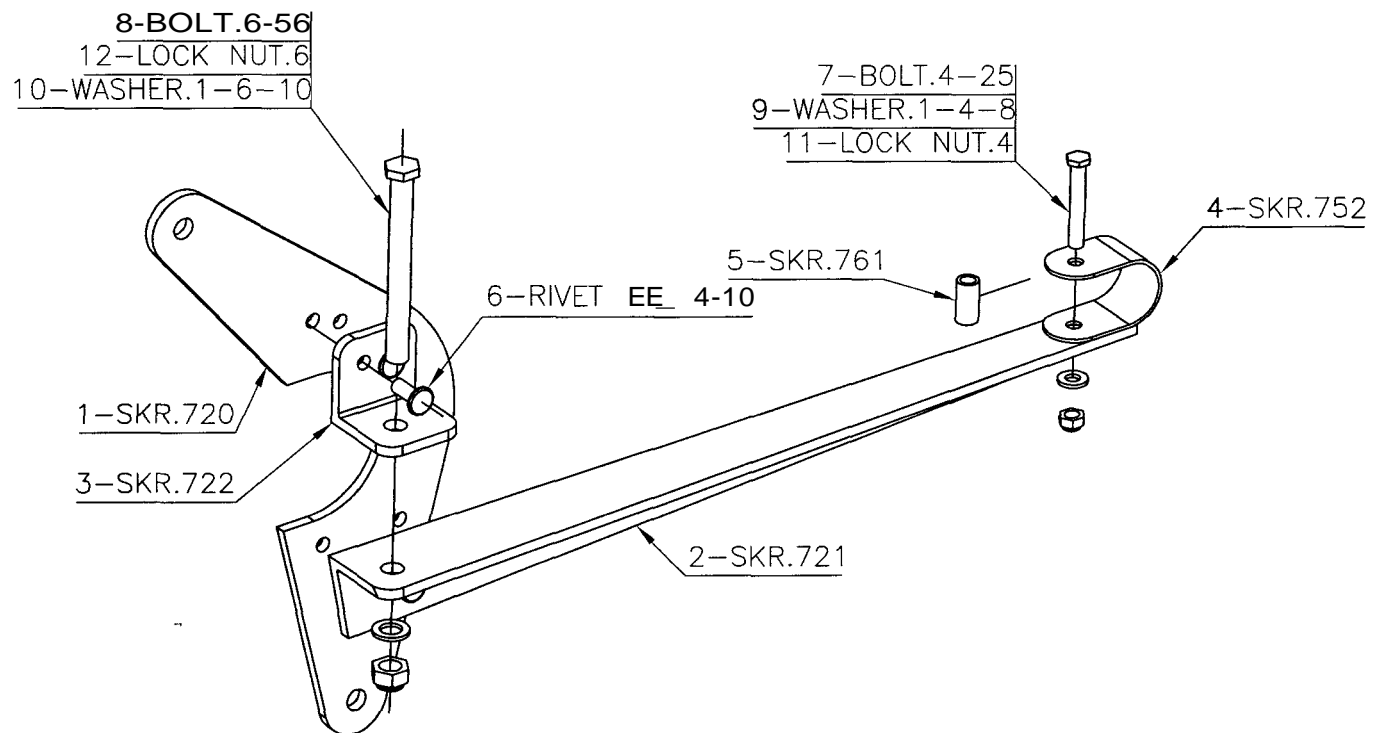

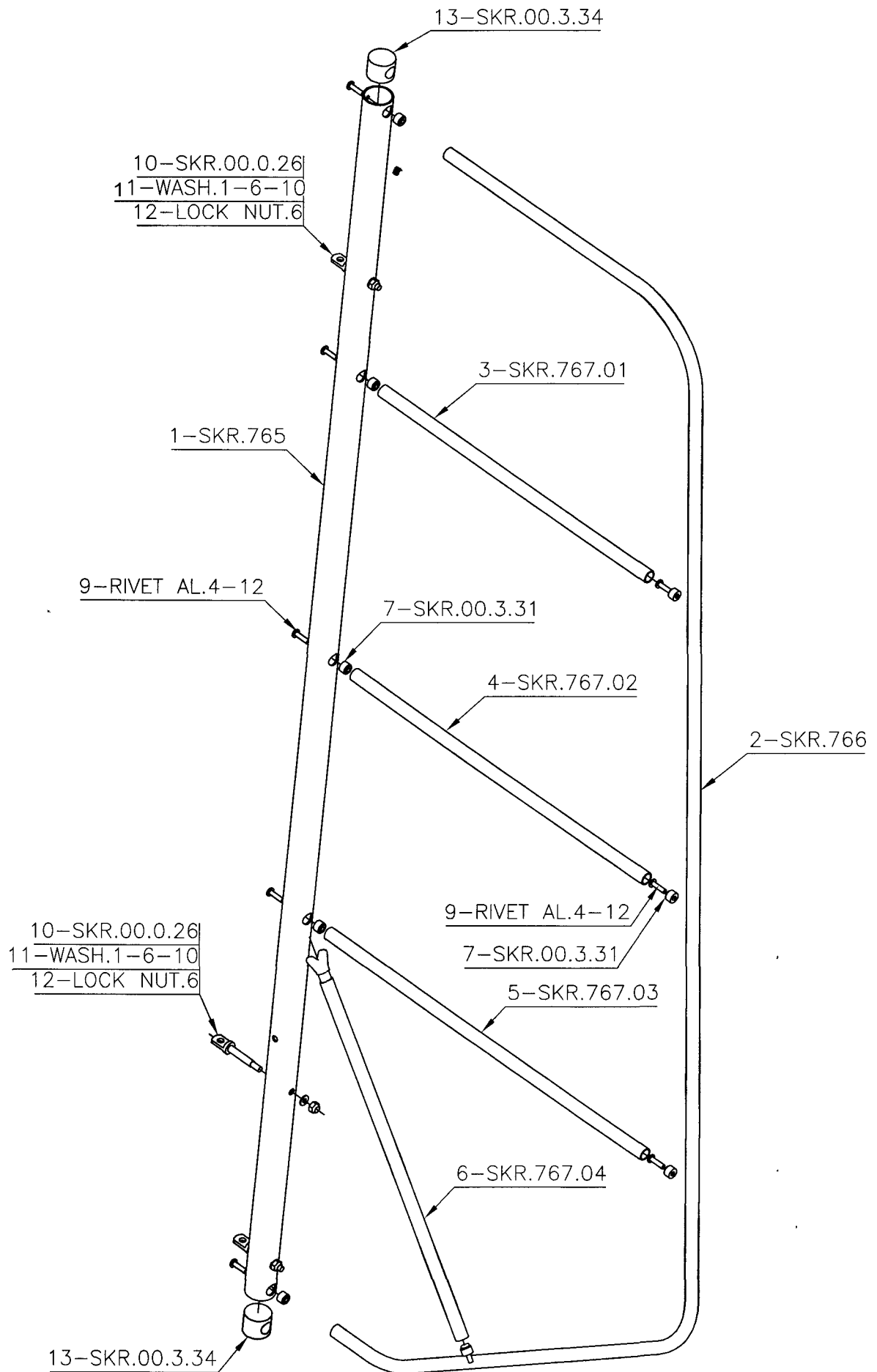

SKR. TK. 75

